

CNC Plasma&Flame Cutting Control System Manual

(Ver. 2.3)

(Model : 2300)

Catalog

CHAPTER 1 SUMMARIZE	1
1.1 BRIEF INTRODUCTION	1
1.2 CHARACTERISTICS OF SYSTEM	1
1.3 TECHNICAL STANDARD.....	1
1.4 SYSTEM INTERFACE.....	2
1.5 HARDWARE CONFIGURATION	3
CHAPTER 2 SYSTEM BOARD AND MAIN INTERFACE.....	4
2.1 INTRODUCTION OF OPERATING BOARD.....	4
2.2 POWER ON PROCESS AND MAIN INTERFACE.....	4
2.3 FUNCTION INDEX OF MAIN INTERFACE.....	7
CHAPTER 3 CUTTING FUNCTION	9
3.1 CUTTING OPERATION INDEX.....	11
3.2 SPEED REGULATION	12
3.3 FORWARD	12
3.4 BACKWARD	12
3.5 EDGE CUTTING / OFFSET CUTTING / RETURN.....	13
3.6 BACK TO REFERENCE FUNCTION.....	14
3.7 OXYGEN GAS PREHEAT TIME REGULATION.....	15
3.8 PERFORATION POINT SELECTION.....	16
3.9 DYNAMIC AMPLIFICATION.....	17
3.10 CUTTING EXIT.....	17
CHAPTER4 PART OPTIONS.....	19
4.1 XY MIRROR	19
4.2 ANGLE ADJUSTMENT	20
4.3 ARRAY.....	21
4.4 ZOOM IN/OUT	25
4.5 SELECT ROW/NUMBER	26
4.5.1 Select row	27
4.5.2 select number.....	29
4.5.3 operation after select row/number	29
4.6 RESTORE	30
CHAPTER 5 MANUAL FUNCTION.....	31
5.1 FIXED MOVING FUNCTION	31
5.2 CONTINUOUS MOVING FUNCTION.....	32
5.3 FIXED-LENGTH MOVING	32
5.4 BREAKPOINT RECOVERY	32
CHAPTER 6 FILE OPERATION	34

6.1 FILES IN THE HARD DISK.....	34
6.2 FILES IN THE U DISK.....	35
6.3 SEARCH FILE.....	37
6.4 EDIT CODE.....	37
6.5 NEW CODE.....	38
6.6 COMPILE CODE.....	38
CHAPTER 7 PARAMETER SETTING.....	39
7.1 COMMON PARAMETERS.....	39
7.2 FLAME PARAMETERS.....	40
7.3 PLASMA PARAMETERS.....	42
7.4 POWDER PARAMETERS.....	43
7.5 SYSTEM PARAMETERS.....	44
7.6 PARAMETER IMPORT.....	46
7.7 PARAMETER EXPORT.....	47
7.8 SAVE PARAMETERS.....	47
CHAPTER 8 DIAGNOSIS FUNCTION.....	49
8.1 DIAGNOSIS INTERFACE INDEX.....	50
8.2 INPUT DIAGNOSIS.....	50
8.3 OUTPUT DIAGNOSIS.....	50
8.4 KEY-PRESS DIAGNOSIS.....	51
8.5 SYSTEM SELF-CHECK.....	52
8.6 DATE AND TIME.....	53
8.7 SYSTEM DEFINITION.....	54
8.7.1 Parameter backup and restore.....	54
8.7.2 Input definition.....	55
8.7.3 Output definition.....	55
8.7.4 Coordinate definition.....	56
CHAPTER 9 GRAPH.....	58
9.1 CHOOSE GRAPH.....	58
9.2 FILM/HOLE SIZE.....	59
CHAPTER 10 PORT EXPLANATION.....	61
10.1 INPUT PORT.....	61
10.1.1 Input Wiring Instructions.....	63
10.1.2 Remote Input.....	64
10.1.3 Input Configuration.....	65
10.2 OUTPUT PORT.....	67
10.2.1 Output Wiring Instructions.....	68
10.2.2 Output configuration.....	72
10.3 MOTOR PORT.....	74
10.3.1 Typical wiring diagram of the electrical motor interfaces.....	75
10.3.2 Coordinate Mapping.....	79

CHAPTER11	INSTALLATION AND DEBUGGING	80
11.1	HORIZONTAL / VERTICAL PULSES NUMBER SETTING	80
CHAPTER12	THE USE OF BIOS	81
12.1	SYSTEM UPGRADE	82
12.2	WELCOM INTERFACE UPGRADING	82
12.3	MOVEMENT CONTROL UPGRADE	82
12.4	MOVEMENT BACKUP	82
12.5	SYSTEM RESET	82
APPENDIX 1	G、M CODE RAPID CONSULT	83

CHAPTER 1 SUMMARIZE

1.1 BRIEF INTRODUCTION

The digital controller 2300 is a new production, which is integrated many merits of the same productions at home and aboard. The controller can control the motion of two axis, which is apt to the application of flame or plasma cutting. This controller is very light and handy and it is very easy to operate. The controller provides menu or illustration for all the operations for the convenience of users. All key switches are human oriented designed, and they are very convenient and comfortable.

The controller chooses high speed DSP and ARM as its core to assure the cutting process to be more stable. The motion control algorithm is optimized so that the machine can move more stable and reliable, and it can save the life of the motor and the mechanical parts.

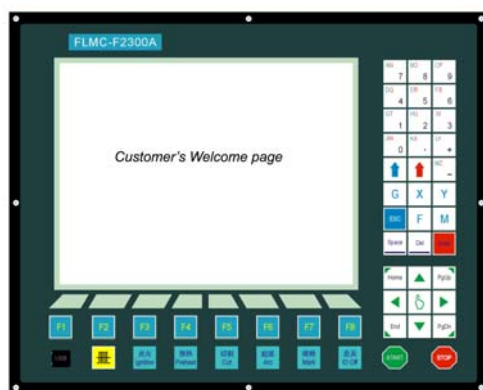

Fig 1.2 2300A



2300B

1.2 CHARACTERISTICS OF SYSTEM

- 1) 10.4 inches 800*680 dots color LCD.
Man-Machine-Dialog software and Professional Hot Key design for easy cutting operation, user-friendly as Hypertherm's EDGE controller.
- 2) Multi-language file system and menu, and the menu can be switched only by one key.
- 3) **DSP core can control the machine move in high speed accurately, stably and in low noise.**
- 4) Long-distance remote control can control the machine to move forward ,backward, left, right and cutting start, stop and so on (optional configuration).
- 5) Support the EIA code (G code) and various FastCAM, FreeNest, SmartNest, IBE softwares.
- 6) compact keyboard design and easy to input files.
- 7) Operations such as Proportion Zoom, Rotate, Mirror, Array display, Steel plate angle adjust.....all available and have professional solution in the CNC controller.

- 8) Coordinate system can be customized to support the two-dimensional coordinates of all eight kinds.
- 9) All input and output port type and the number can be customized (normally open or normally closed)
- 10) System Self-diagnosis for easy trouble-shooting.
- 11) all functions and techniques can upgrade online
- 12) Import and export files by single or all files.
- 13) Support the Flame, Plasma, Dusting draw and Demonstration four kinds of mode.
- 14) Flame and Plasma are separated in the control IO ports.
- 15) Support THC, two level preheat, three level pierce in flame mode.
- 16) Plasma arc feedback, positioning feedback, automatically shut down the arc at the corner.
- 17) Support edge cutting. It can save the preheat time for the thick steel plate.
- 18) Movement speed can be real-time acceleration, deceleration.
- 19) According to plate thickness, the cutting speed is automatically restricted by a speed limit in the corner, effectively preventing over burn.
- 20) Dynamic/static illustration of the process, graphics zoom in / out, dynamically tracking cut-off point under zooming state.
- 21) Automatically memorize the working situation and the last cutting point when power off.
- 22) "Cutting offset" function can avoid waste the steel plate when the nesting of the plate is calculated wrong.
- 23) set up different administration authority and the corresponding password to safeguard the interests of managers.

1.3 TECHNICAL STANDARD

- 1) Control Axis: 2
- 2) Control accuracy : +/-0.001mm
- 3) Coordinate range: +/- 99999.999mm
- 4) Max pulses : 200kHz Max speed: 15000 mm/m
- 5) Max lines of code: 150000lines
- 6) Max size of single code file: 4M

- 7) Time resolution : 10ms
- 8) Working Voltage: DC 24V in put
- 9) Working Temperature: -10°C-60°C. Relative Humidity, 0-95%.

1.4 SYSTEM INTERFACE

- 1) 15 pins interface of 2 axis of motor drive.
- 2) 25 pins interface of 16 channels optical couple output ports, max back flow current 300mA.
- 3) 25 pins interface of 16 channels optical couple input ports, max output current 300mA.
- 4) USB interface on the front panel.
- 5) Extend IO input/output ports, PWM input ports, analog input ports.

1.5 HARDWARE CONFIGURATION

- 1) Monitor:15 inch, 1024*768, high definition 16 million colors and high brightness LCD or 10.4 inch 800*600, 26 million color LCD.
- 2) Memory: 64M SDRAM
- 3) Memory available for user: 256M or 1G electronic hard disk
- 4) System master frequency: 400MHz
- 5) USB: USB 1.1 front interface
- 6) Keyboard: electronic PCB foil keyboard(one machine) or standard industrial keyboard(split type machine)
- 7) Chassis: full-steel structure completely shielded which defends electromagnetic radiation, interference and static electricity.

CHAPTER 2 SYSTEM BOARD AND MAIN INTERFACE

2.1 INTRODUCTION OF OPERATING BOARD

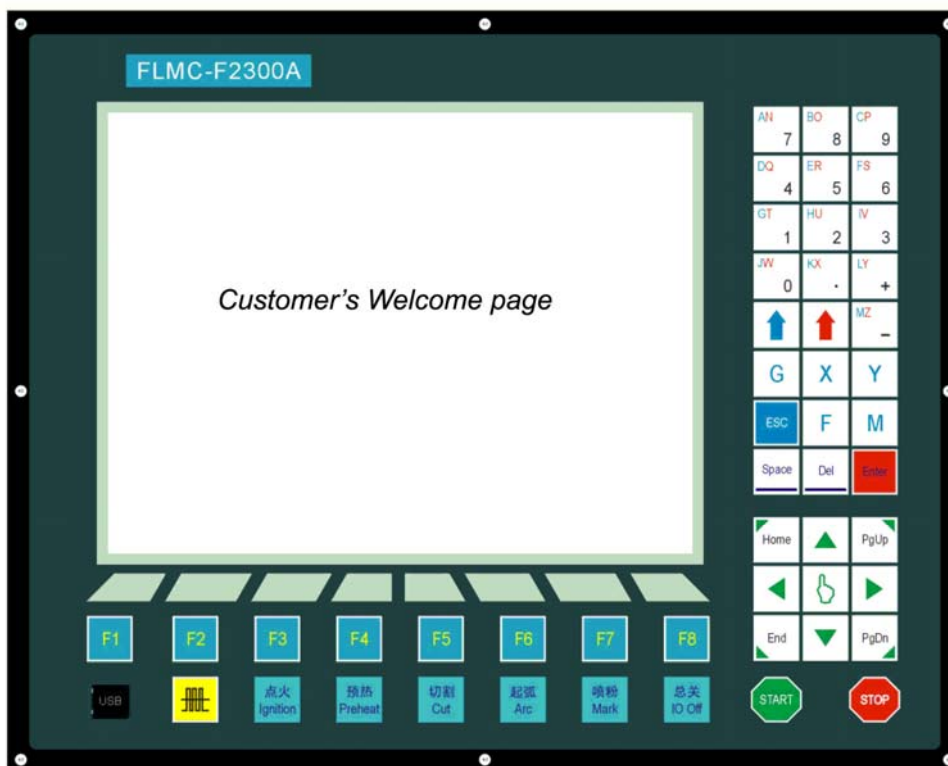

Fig 2.1 board and keys

- 【F1】 - 【F8】: Function key in different interface
- 【S ↑ /PgUP】: page-up key of code interface or Torch up in other interface
- 【S ↓ /PgDn】: page-down key of code interface or Torch down in other interface
- 【F+ /HOME】: Accelerate or skip to the head of code line
- 【F- /END】: Decelerate or skip to the tail of code line
- 【1】 - 【9】: during the cutting process, change the cutting speed to ratio of the speed limit you have set, for example press 【1】, change the cutting speed to 10% of the speed limit you have set, press 【2】, change the cutting speed to 20% of the speed limit you have set

2.2 POWER ON PROCESS AND MAIN INTERFACE

When power just on, the system will go for the process of self scan:

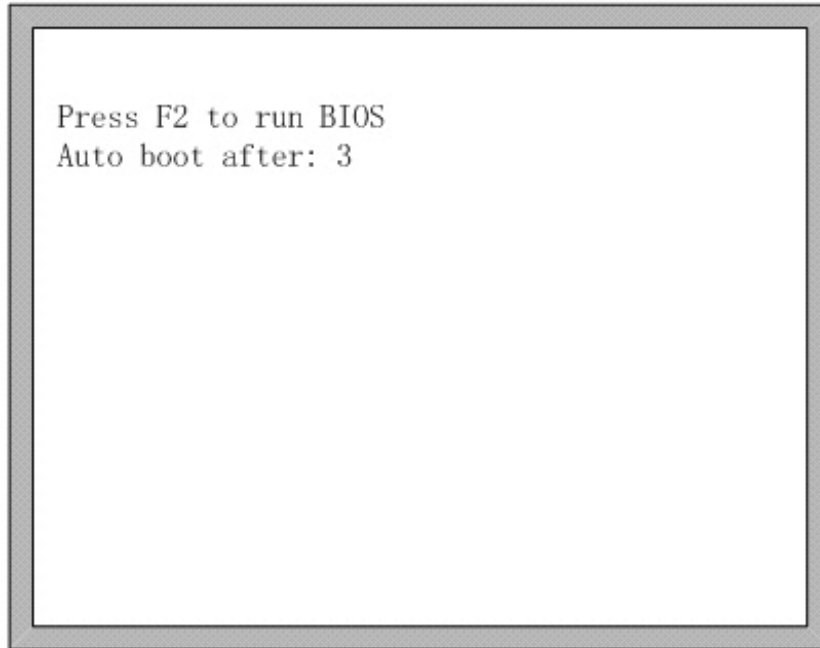

Fig 2.2 system self scan

In the starting process, there is 3 seconds to countdown, before the countdown is over, if pressing **【F2】**, it will enter the bios starting interface shown as Fig2.3 (please take the reference of the appendix 2 to run bios). If pressing any other key, it will jump over the countdown and directly enter the welcome interface. If pressing no key, it will countdown to 0 and then enter the welcome interface shown as Fig2.4.

- F1 - 系统升级(System software update)
- F2 - 欢迎界面升级(Welcome picture update)
- F3 - 运动控制升级(Motion update)
- F4 - 系统备份(System backup)
- F5 - 系统还原(System recovery)
- F6 - 启动系统(Start system)

Fig 2.3 bios interface

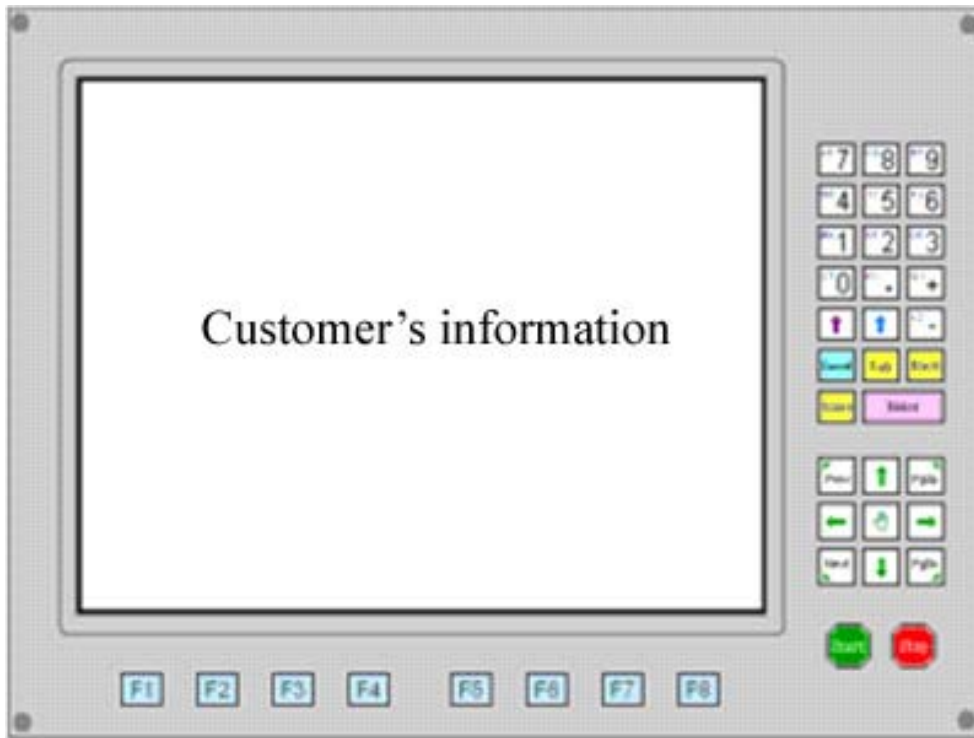

Fig 2.4 welcome interface

In the welcome interface, press any key to enter the main interface automatically shown as Fig2.5:

FLSK F2500 Version 3. 3. 71. 1		Speed: 00000	File: SHAPE 43. TXT	Status:	Current Line/Hole: 00000/00000		
				<ul style="list-style-type: none"> ● Ignition s ● LowPreheat s ● HighPreheat s ● Pierce 1 s ● Pierce 2 s ● Pierce 3 s ● TorchUp s ● TorchDn s ● THC En s ● Exhaust s 			
				CutSpeed [X] 1000.00 Kerf [Z] 1.20 ManualSpeed [Y] 3000.00 Angle 0.00 Manual [F] keepMov StepMov ContiMov StepDis [G] 5.00 Flame Cu [G]			
+X:500.00 -X:0.00 +Y:500.00 -Y:0.00							
00001: (TEST PATTERN) 00002: G92							
F1 ShapeLib	F2 Files	F3 PartOption	F4 Setups	F5 Diagnose	F6 ZoomIn	F7 ManualMove	F8 Zero

Fig 2.5 the main interface

In the main interface, press **【F1】** - **【F8】** for the following functions:

【F1】: ShapeLib: pressing F1 to enter the Shape Library including 45 common shape, and most of them have plate size and hole size.

【F2】: Files: You can load local files, U disk files or edit, import, export and delete codes.

【F3】: PartOption: make actions of mirroring, rotation, plate adjusting, plate arraying, selecting row and hole or code edition etc.

【F4】: Setups: setting all parameters.

【F5】: Diagnose: including input ports diagnosis, output ports diagnosis, keyboard diagnosis, system self check, date setting and system self defines.

【F6】: ZoomIn: Zoom in the shape in full screen.

【F7】: ManualMove: Manually move the machine.

【F8】: Zero: Clear the coordinate of X and Y before starting cut or after cutting over.

【X】: CutSpeed: Setting the cutting speed.

【Y】: ManualSpeed: Setting the manual moving speed.

【Z】: Kerf: Setting the kerfs' compensate value.

【F】: Manual: Setting the mode of manual movement including keepMov(keep movement), StepMov(step movement), ContiMov(continue movement). The selected mode is black background.

【G】: StepDis: Setting the distance of the fixed-length.

【M】: Selecting the cutting mode including Flame Cu(flame cutting), Plasma C(plasma cutting), Demo run.

2.3 Function index of main interface

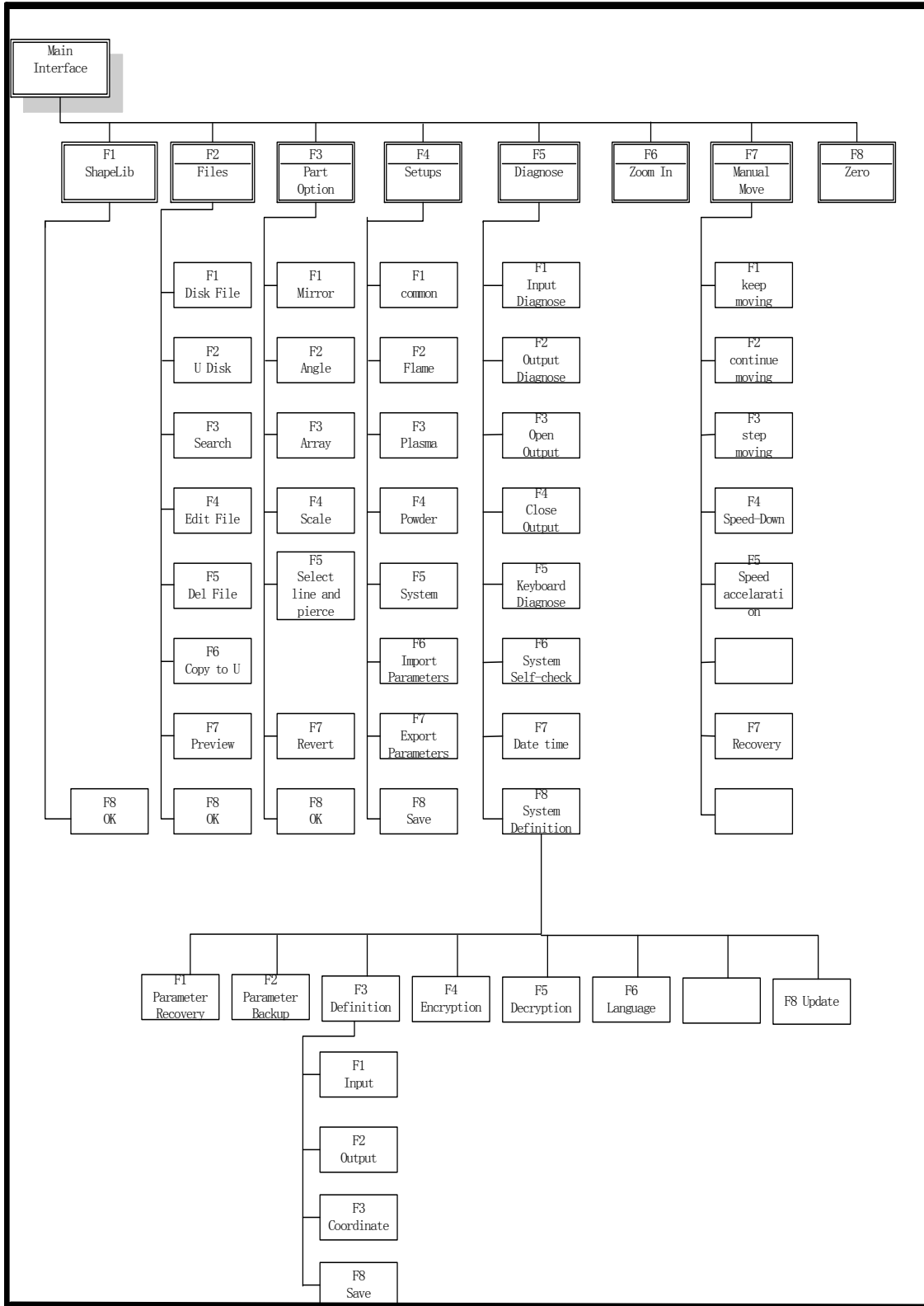

CHAPTER 3 CUTTING FUNCTION

In the main interface, press the **【SPACE】** to enter the cutting interface, shown as follows:

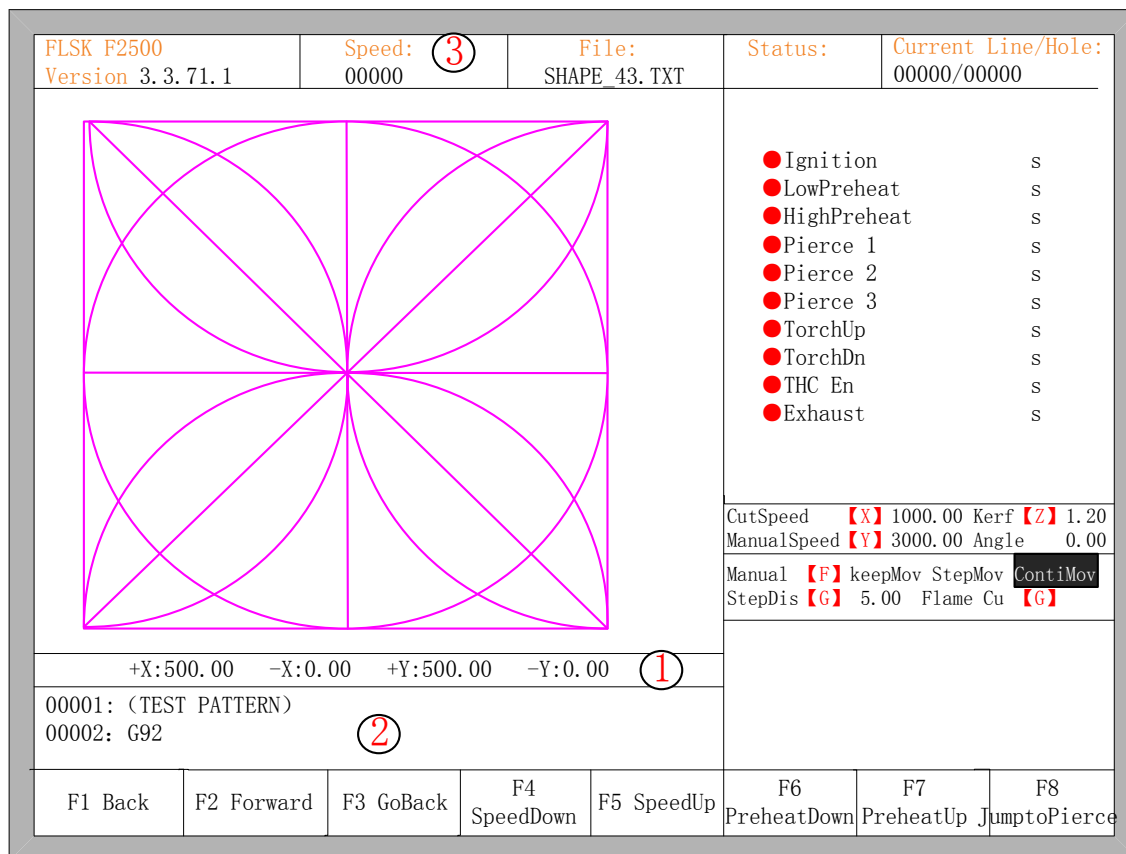

Fig 3.1 cutting function interface

Show the current workpiece's cutting path, including the slotted value.

Show the G-code being processed, shows the current and next line.

Show the current cutting speed, during processing, you can press the keyboard's number keys **【1】** - **【9】** to achieve quick speed regulation. For example, press the number **【3】**, the speed is automatically adjusted to 30%; press the number **【8】** the speed is automatically adjusted to 80%.

X shows the absolute coordinate of the torch in X direction.

Y shows the absolute coordinate of the torch in Y direction.

In the cutting interface:

- Press **【X】**: Modify the current maximum cutting speed.
- Press **【Y】**: Modify the current maximum speed manual shift car.
- Press **【F】**: Change the current manual method.
- Press **【G】**: Modify the current fixed-length fixed long-distance move.
- **【START】** (**【F9】**): Start cutting.
- **【STOP】** (**【F10】**): Parking, the system can suspend all ongoing actions.
- **【F1】**: The torch move back along the cutting path(I / O port closed)

- **【F2】** : The torch forward along the path (I / O port closed).
- **【F3】** : Return to the starting point of cutting torch, i.e. the starting point of the current work piece.
- **【F4】** : Decrease the cutting speed, each decrease of 1% click rate.
- **【F5】** : Increase the cutting speed, each 1% increase in click rate.
- **【F6】** : Reduce the preheat time, skip the remaining preheat time, and the system automatically records preheat time.
- **【F7】** : Increase the preheat time once 15 seconds.
- **【F8】** : When the system is suspended, for selecting perforation point; when the system begins to move, for the dynamic amplification.
- four direction keys (Up, down, left and right): When the gun through, manually move the torch.

3.1 Cutting Operation Index

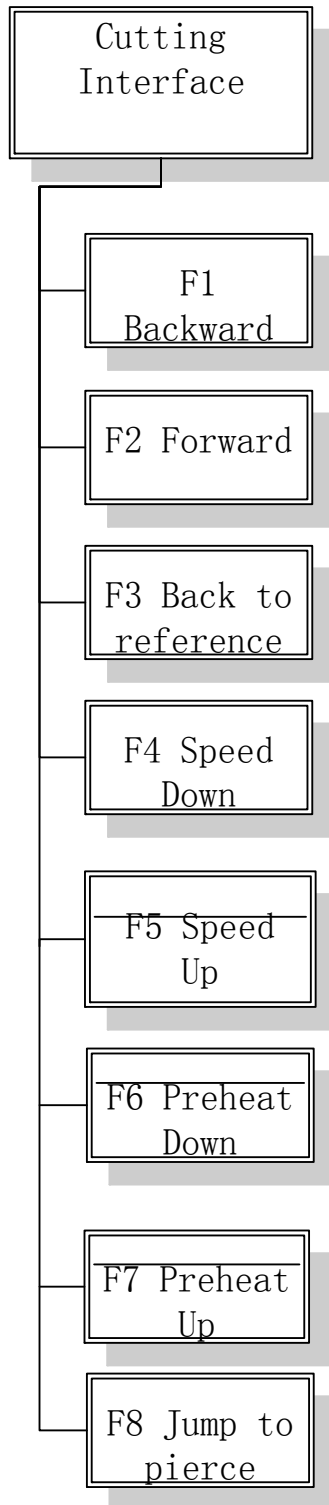

Automatic operation index

3.2 Speed Regulation

3.2.1 Normal Speed Regulation

In automatic operation, or when the system is suspended, in the cutting interface the system can regulate speed.

The operation panel, press **【F5】** or **【PRE】**, increasing at a rate per click rate of 1%. Hold the **【F5】** or **【PRE】**, then the rate will continuously increase to 100%. Increased to 100%, the speed is "common parameters" in the "cutting speed."

The operation panel, press **【F4】** or **【NEXT】**, each click rate of speed reduced by 1%. Hold the **【F4】** or **【NEXT】**, then the rate will be continuously reduced to 1%. Reduced to a very slow speed when running in order to ensure the accuracy requirements, the system may auto-adjust the speed based on the size of "horizontal pulses" and "vertical pulses", actual speed may not be the "cutting speed" of 1% is greater than 1%.

3.2.2 Quick Speed Regulation

In automatic operation, or when the system is suspended, in the cutting interface the system can carry out quick speed regulation.

In the cutting interface, on the operation panel, press the number keys **【1】** - **【9】**, the speed will quickly adjust to the corresponding percentage figures 10 times, for example press **【3】**, adjust to 30% of the speed limit you have set, press **【8】**, adjust to 80% of the speed limit you have set.

3.3 Forward

In the automatic function interface, press key **【F1】**, the machine start to move without real cutting. The process does not include any ignition, perforation and any other I/O working. The machine just moves the torch according to the graphic figure.

The function can be used to check the trail and code before you start the real cutting process, or can also be used when the process needs through the gun. Press the red "STOP" key to stop the null cutting process if you want.

3.4 Backward

During the running process, if you want to go backward according to the origin trail to (maybe the iron board was not cut through), you can follow the following direction:

- First, press "STOP" key to set the machine at pause status.
- In the automatic function interface, press key **【F3】** (Back) to make the machine go backward along with the original trail. When the torch reaches the position you need, press "STOP" key to stop it. You may press key **【F2】** to go forward if the machine just went back too much.

Notice: Go backward or forward function can be used repeatedly to make the machine reach an ideal position.

- When the torch reaches the position you need, press "START" key again, if the current cutting code is G01, G02 or G03, system will automatically perforate before performing these

procedures, and then continue the current program, if the current row is not G01, G02 or G03, the system will directly continue the current line program.

3.5 Edge Cutting / Offset Cutting / Return

When the torch is not on the actual path of the current work piece, it will prompt as follows:

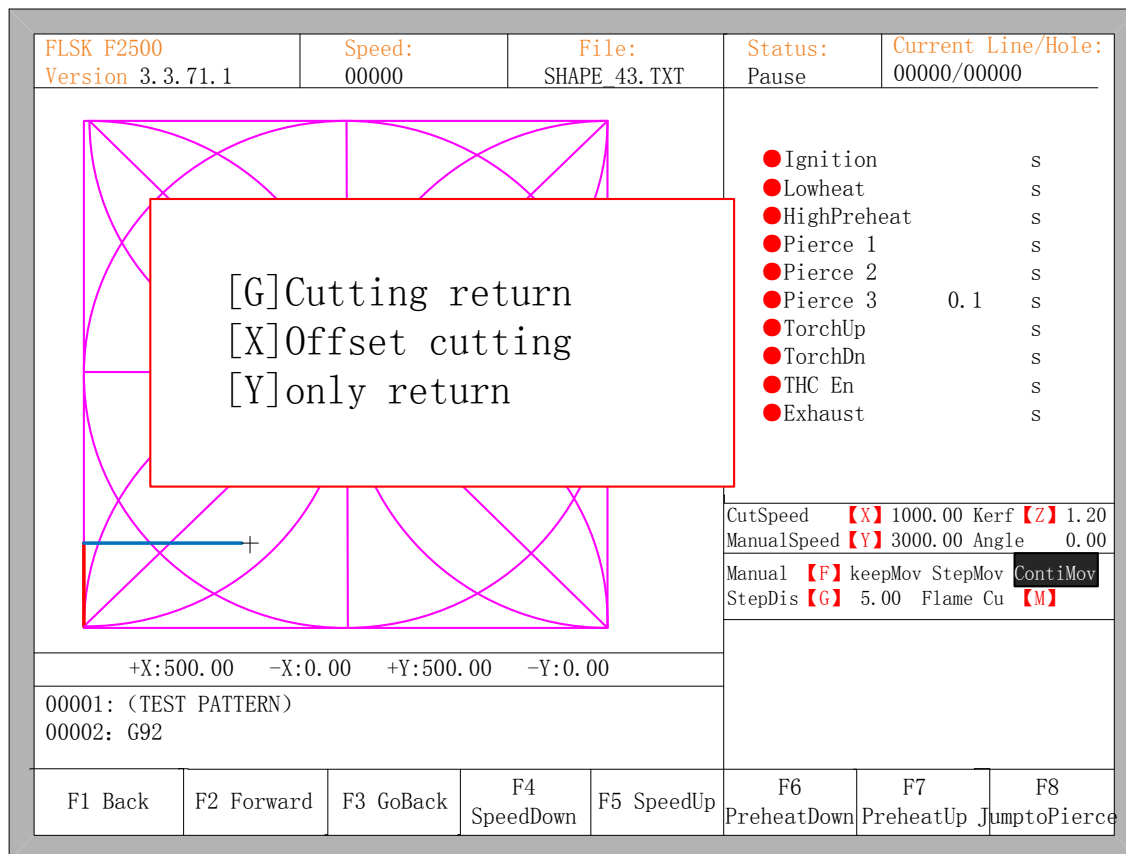

Fig. 3.2 edge perforation

There are two reasons led to this situation:

(1) When the common parameter "edge perforation" selects "Yes" and the next processing line G-code is M07, the system will be automatically suspended. At this time, the torch can be manually moved to any edge of the plate, press the "start" button, the system will prompt as above

(2) When the processing is paused, due to mechanical failure or other reasons, it needs to move the torch out of the actual path of the workpiece, the above prompt will appear.

- If press **【G】**, the system cutting returns back to the paused point, continue to cut it. This feature is particularly useful for thick steel plate, it can reduce the preheat time and increase cutting efficiency. This function is the commonly-used edge perforation function.

- If press **【X】**, the system considers current point is the paused point, it will continue cutting it. That is, the system offsets the cutting point. When the cutting machine paused or a power outage, if the cutting tip or steel plate with the pan has been offset, or the user would like to think that is offset cutting, you can press this button.

- If press **【Y】**, The system only return to the paused point quickly, and then break off. During the cutting process, if discovery cutting torch malfunction, or other issues, need to move the

cutting tip out of cutting region to overhaul. After the maintenance, this key can be pressed. Then return to the paused point, press the "start" button, the system automatically continues to cutting.

3.6 Back to Reference Function

Pause in the processing, if press the **【F3】**, then the system will prompt:

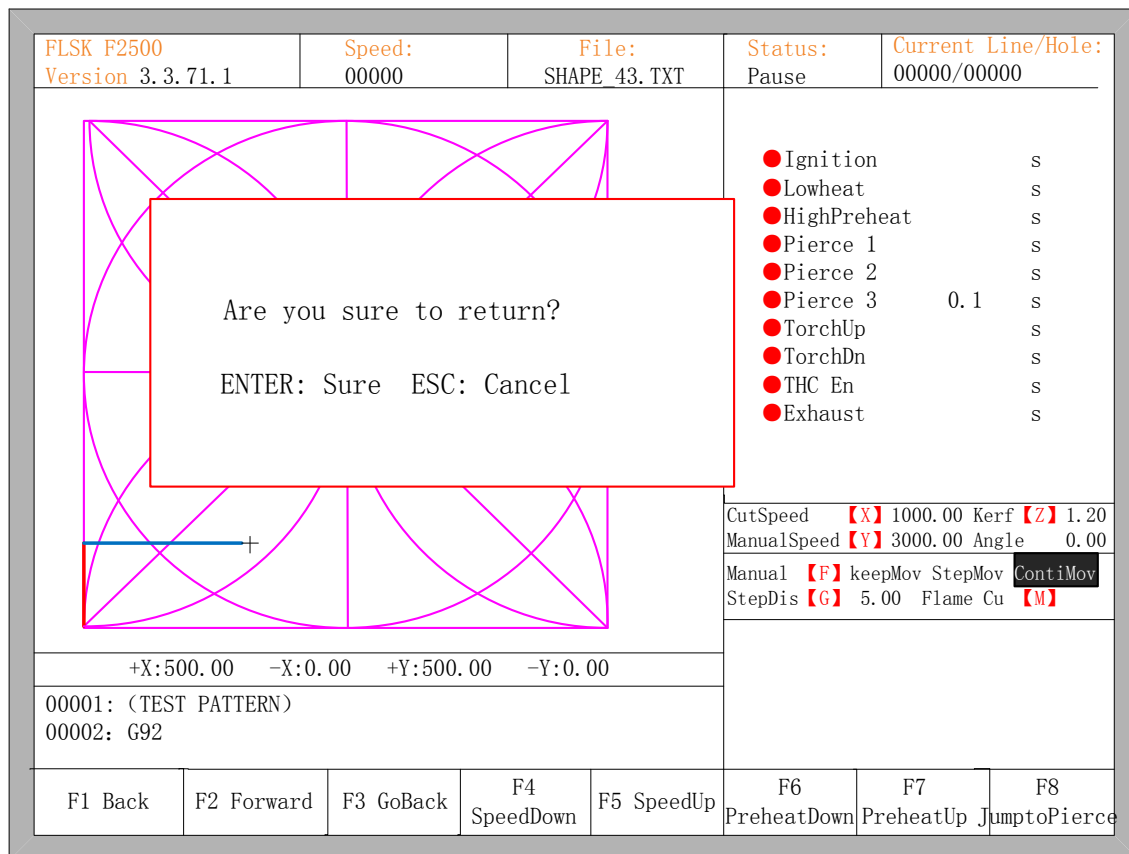

Fig. 3.3 return reference prompt

Press the Enter key, the system will automatically return to the starting point of the work piece, and then the system automatically switches to processing the main interface, and waits for further user action.

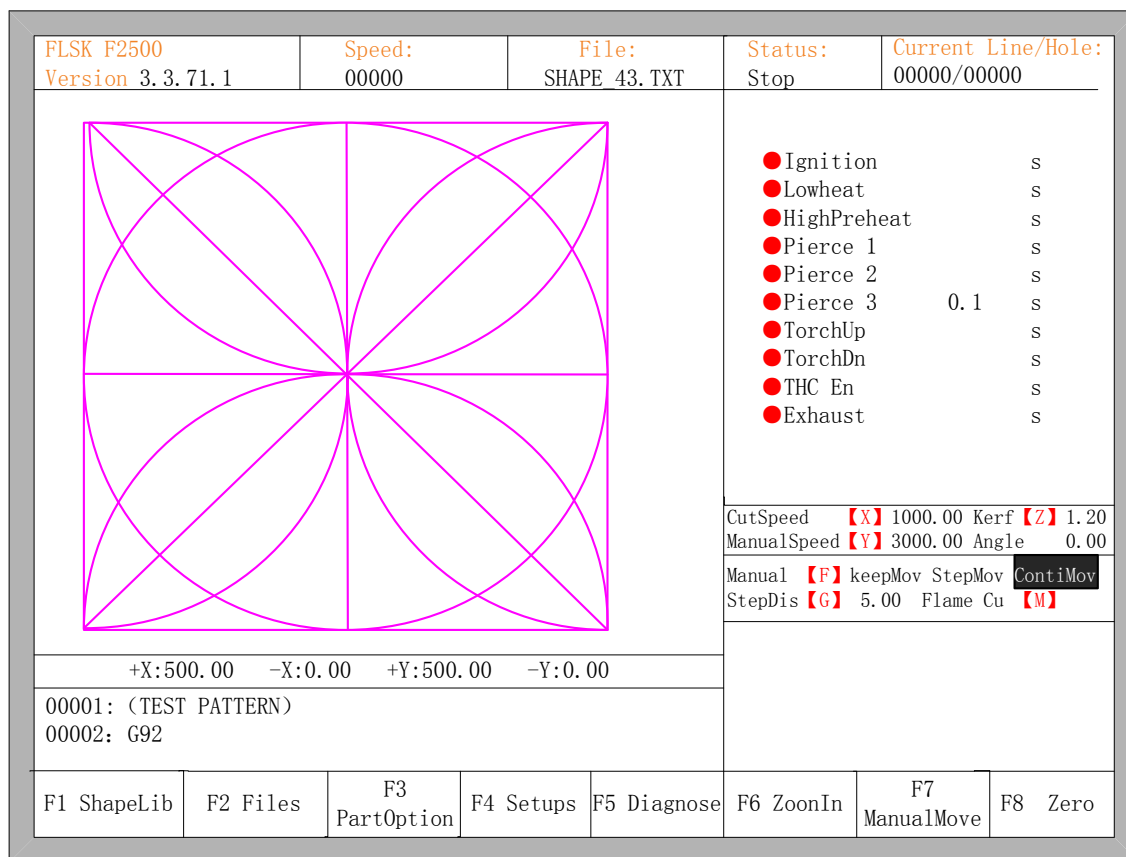

Fig. 3.4 main process interface

During the return process, the user can press the "Stop" button to stop the operation, and can continue to return operation after pressing of **【F3】**. Number of back to reference and stop has no limit.

3.7 Oxygen Gas Preheat Time Regulation

- In the preheat process, press the START (F9) key to skip the process of preheat and perforation delay, and immediately open the perforation signal then begin to cut.
- In the preheat process, press the stop (F10) key to stop preheat, waiting for the F9 key is pressed again.
- In the preheat process, press the F6 key then the preheat time will be reduced to the current preheat time spent, and skip the process of preheat and perforation delay, and open the perforation signal then begin to cut..

For example: the original system sets the preheat time of 60 seconds after null cutting, when preheat needed, the interface will count down, under normal circumstances, till 0, the system begins the next step of cutting, but if the system has the remaining 10 seconds of countdown time, press F6, then the system immediately stops preheat to begin the next step of cutting, and records the preheat time of 50 seconds, the system automatically thinks that users need preheat time of 50 seconds, the next preheat after the null cutting when the preheat time becomes 50 seconds.

- In the preheat process, each press the F7 key, preheat time increases by 15 seconds, and the preheat time maintains the increased value.

For example: The original system sets the preheat time of 60 seconds after the null cutting, during the system countdown, each press F7, on the interface the countdown increases by 15 seconds, and the next time you need to preheat, the initial preheat time be 75 seconds.

3.8 Perforation Point Selection

Before you start cutting or cutting is paused, the function key prompt F8 is "select new pierce", then press F8, the system will prompt:

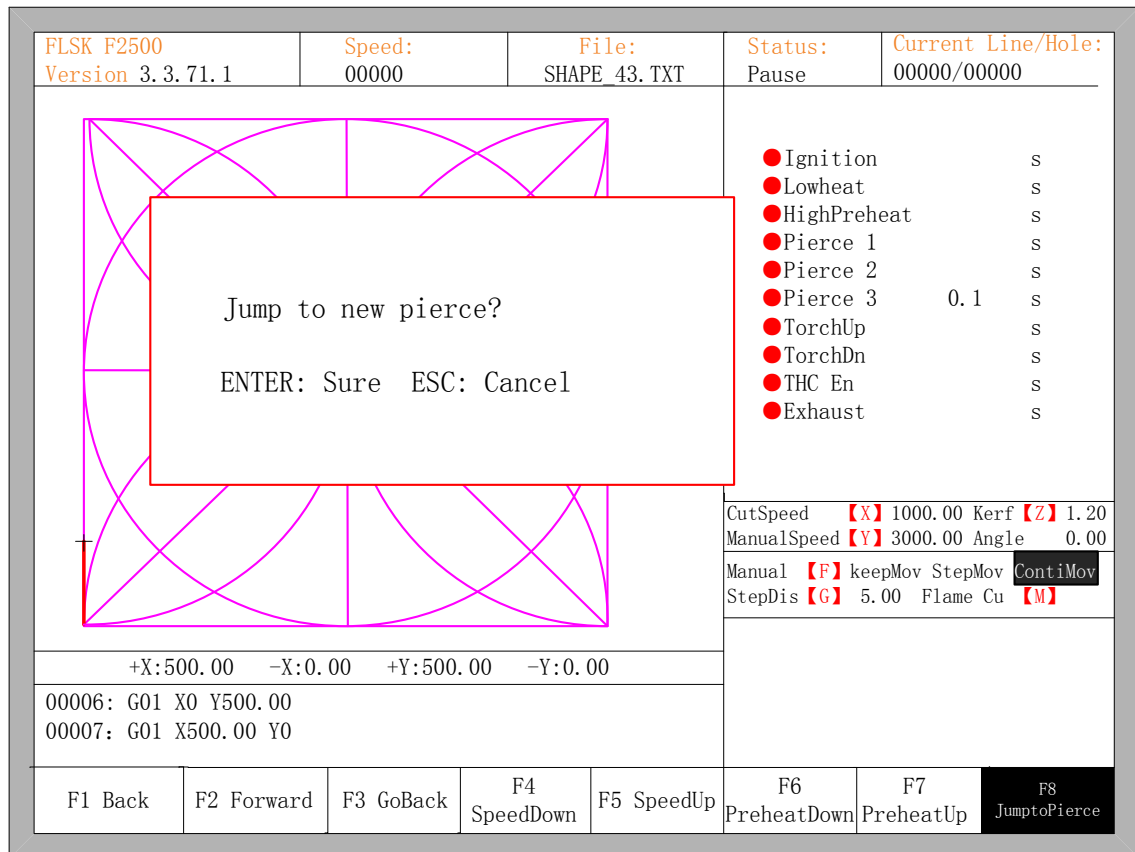

Fig. 3.5 select new pierce

If you press ESC, the system will then return the cutting interface. If you press ENTER, the system will again prompt:

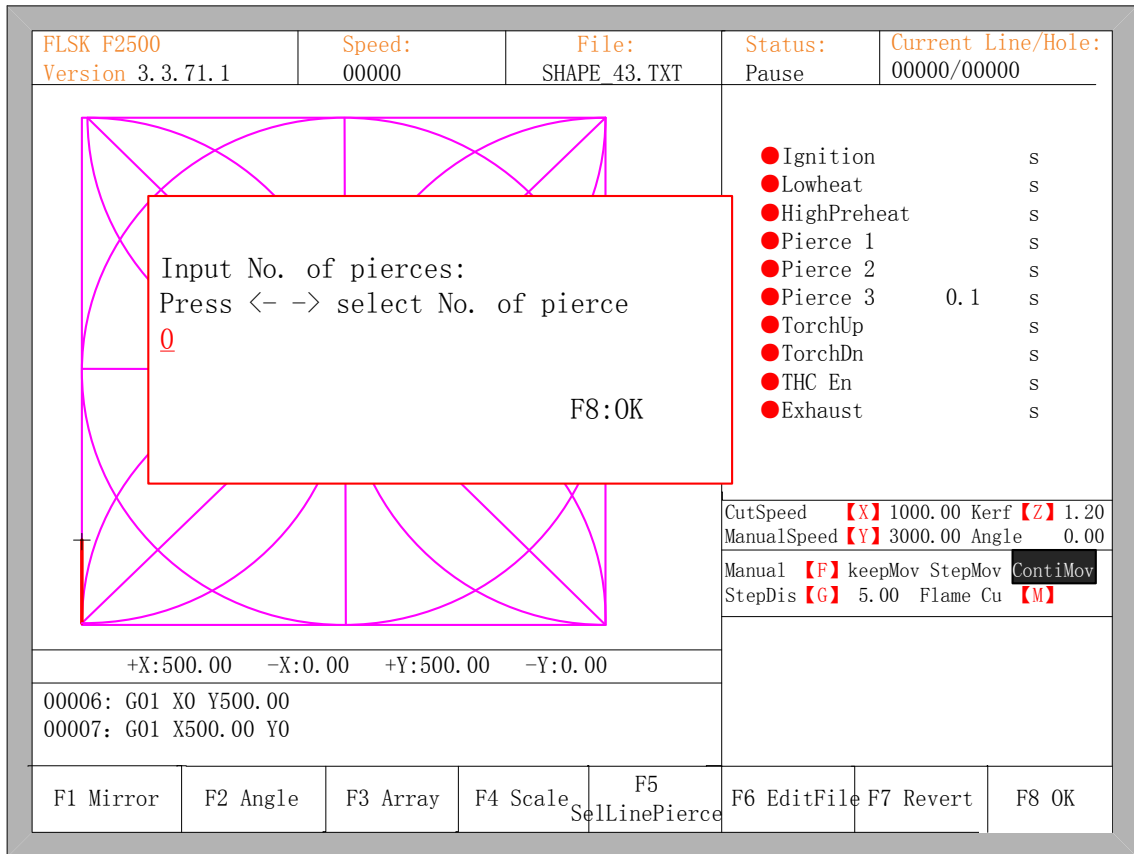
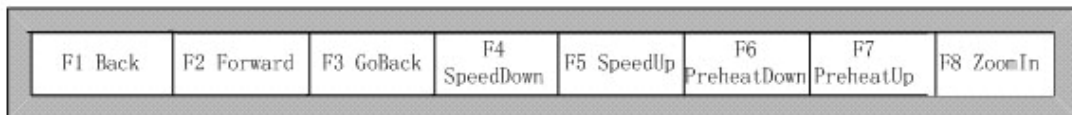

Fig. 3.6 pierce prompt

pierce point can be input manually at this time. You can also press ESC to exit without manual input perforation point, and then press the left and right arrow keys to select the perforation point.

3.9 Dynamic Amplification

After the start of cutting, the F8 in the cutting interface will become "dynamic amplification", then press the F8 key, full-screen amplify the processing graphic, and dynamically tracking.



- Press the F8 key continuously, the system will progressively amplify graphic.
- Press ESC to exit the amplified display, back to the cutting interface.

3.10 Cutting Exit

When the cutting operation does not get finished, and the cutting machine also being in the pause condition, if press 【Esc】, the system will query whether quit the cutting operation. If pressing 【Enter】, the system will exit, and if pressing 【Esc】the system will not exit, get into the automatically interface and go on with the cutting operation at the current place.

FLSK F2500 Version 3.3.71.1		Speed: 00000	File: SHAPE 43.TXT	Status: Pause	Current Line/Hole: 00000/00000		
				<ul style="list-style-type: none"> ● Ignition s ● Lowheat s ● HighPreheat s ● Pierce 1 s ● Pierce 2 s ● Pierce 3 0.1 s ● TorchUp s ● TorchDn s ● THC En s ● Exhaust s 			
				CutSpeed [X] 1000.00 Kerf [Z] 1.20 ManualSpeed [Y] 3000.00 Angle 0.00 Manual [F] keepMov StepMov ContiMov StepDis [G] 5.00 Flame Cu [M]			
+X:500.00 -X:0.00 +Y:500.00 -Y:0.00							
00006: G01 X0 Y500.00 00007: G01 X500.00 Y0							
F1 Back	F2 Forward	F3 GoBack	F4 SpeedDown	F5 SpeedUp	F6 PreheatDown	F7 PreheatUp	F8 JumptoPierce

Fig. 3.7 Quit of cutting

CHAPTER4 PART OPTIONS

Before starting cutting, you can use “F3 PartOption” in the main interface. Press F3 to enter part options menu:

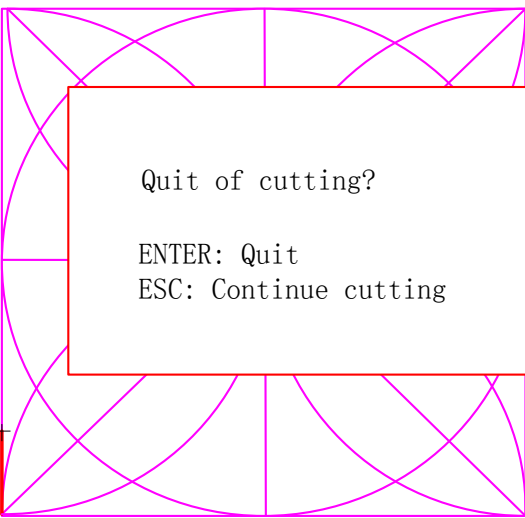
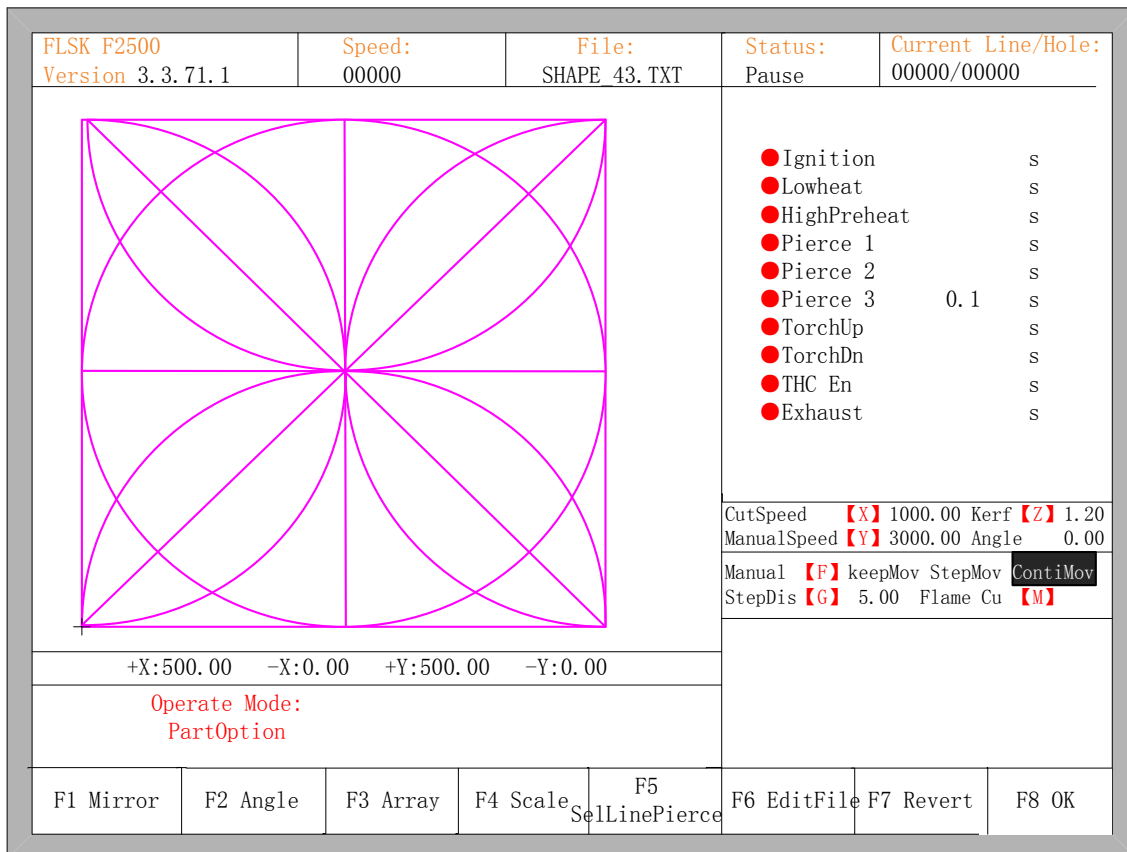
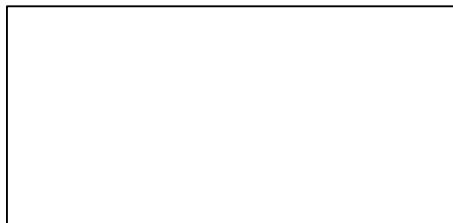

Fig 4.1 Part options

4.1 XY mirror

Press F1, the system will prompt:



- Press F1 to mirror along the horizontal axis(X axis)
- Press F2 to mirror along the vertical axis(Y axis)

- Press ESC to exit mirror operation

4.2 Angle adjustment

Press F2, the system will prompt:

```
F1- Steel plate adjust
F2- enter angle
```

- Press F1 to adjust steel plate
- Press F2 to enter angle directly
- Press ESC to exit angle adjusting

4.2.1 Steel plate adjustment

After entering steel plate adjustment menu, the system will prompt:

```
X-start Y-OK  ESC-exit
Adjust X: +00000.00
Adjust Y: +00000.00
Angle : +00000.00
```

Here, you can manually move the cutting tip to the edge of one side or a corner of the plate. When the cutting tip moved to a good position, press **【X】** key to set the current point as the starting point of correction.

And then manually move along the cutting tip, as long as moving to the edges of the side. After ensuring the two points far enough and two points at the same side of the plate in the same line and press **【Y】**. The system will automatically calculate the current offset angle of plate, and then automatically rotate graphics.

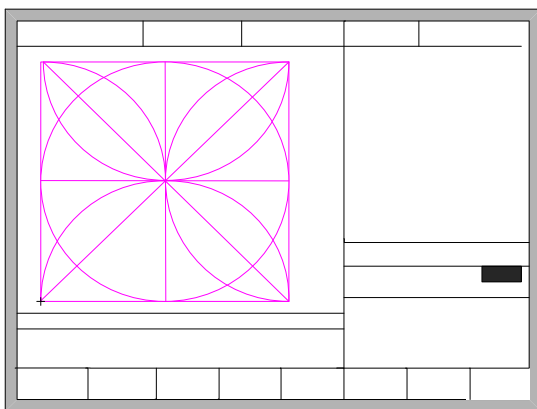

Before adjusting

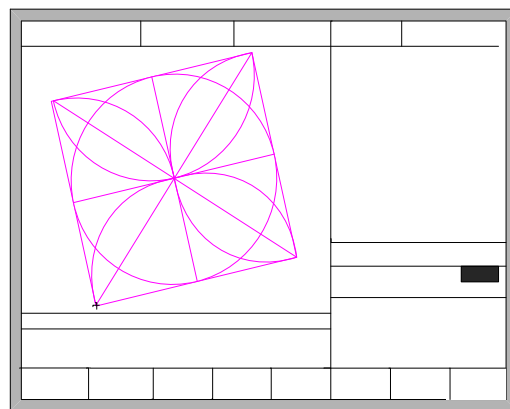

After adjusting

After adjusting, the system will ask whether to return to the start point, if press [ENTER], the system will back to the start point of the operation, if press [ESC], the system will do nothing but

go back to the graphic interface.

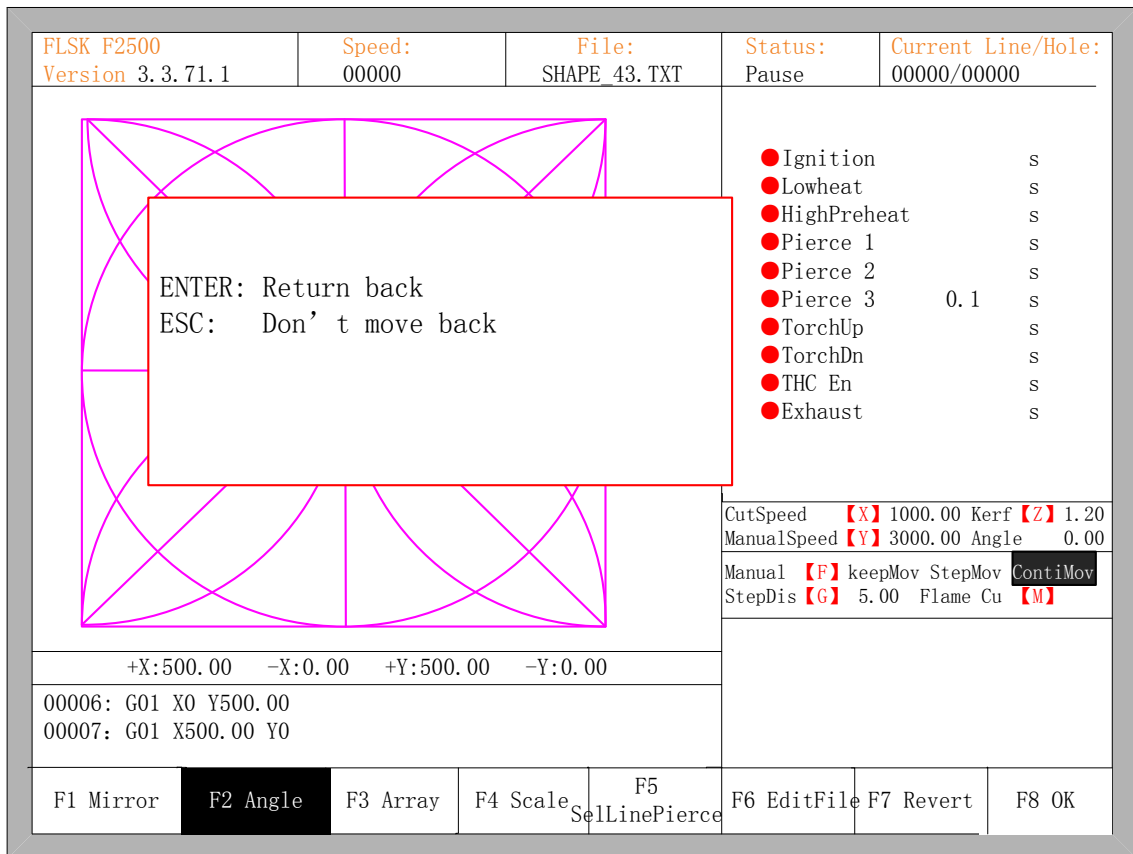

Fig 4.2 Return to the start point after adjusting

4.2.2 Enter angle

When the angle of the current work piece is known, you can enter the angle:

```
Please enter angle
min: -360 max: 360
Angle:      0.00
```

Enter angle

After manually enter the angle, press [ENTER] to make sure, the graphic will be rotate with the corresponding angle. Positive angle means rotate in counterclockwise, while negative means clockwise. Press [ESC] to exit angle adjusting.

4.3 Array

In the part options menu, press [F3], the system will prompt as Fig 4.3, there are three ways to arrange, arrange in matrix, staggered arrange, arrange in stack.

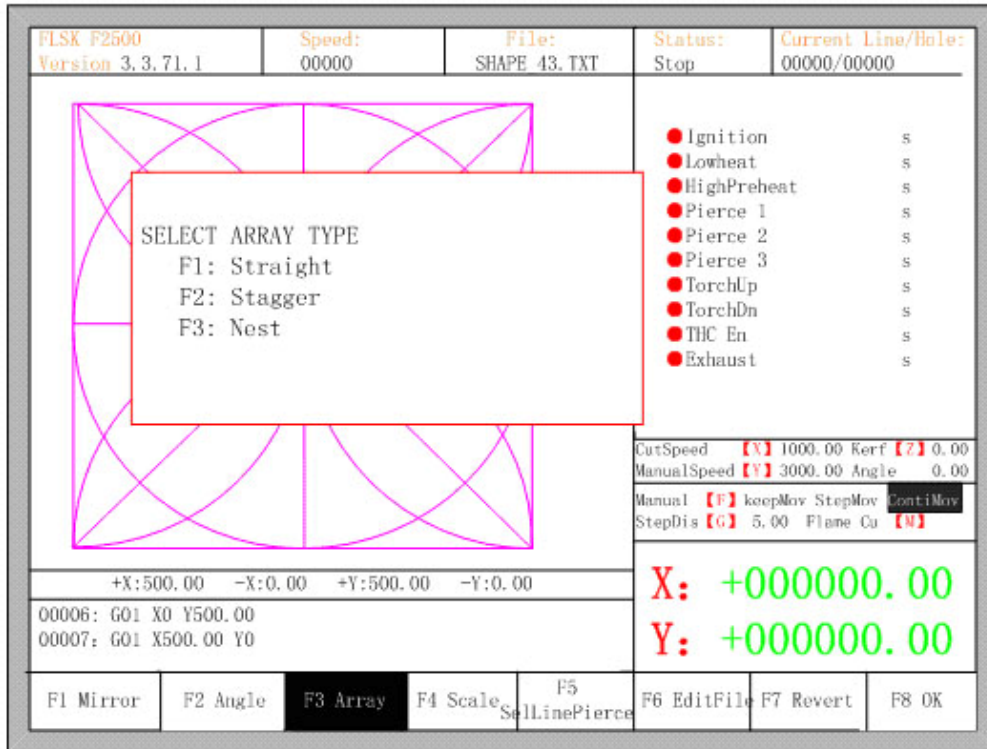

Fig 4.3 chooses arrange method

Press [F1] to carry on arranging in matrix:

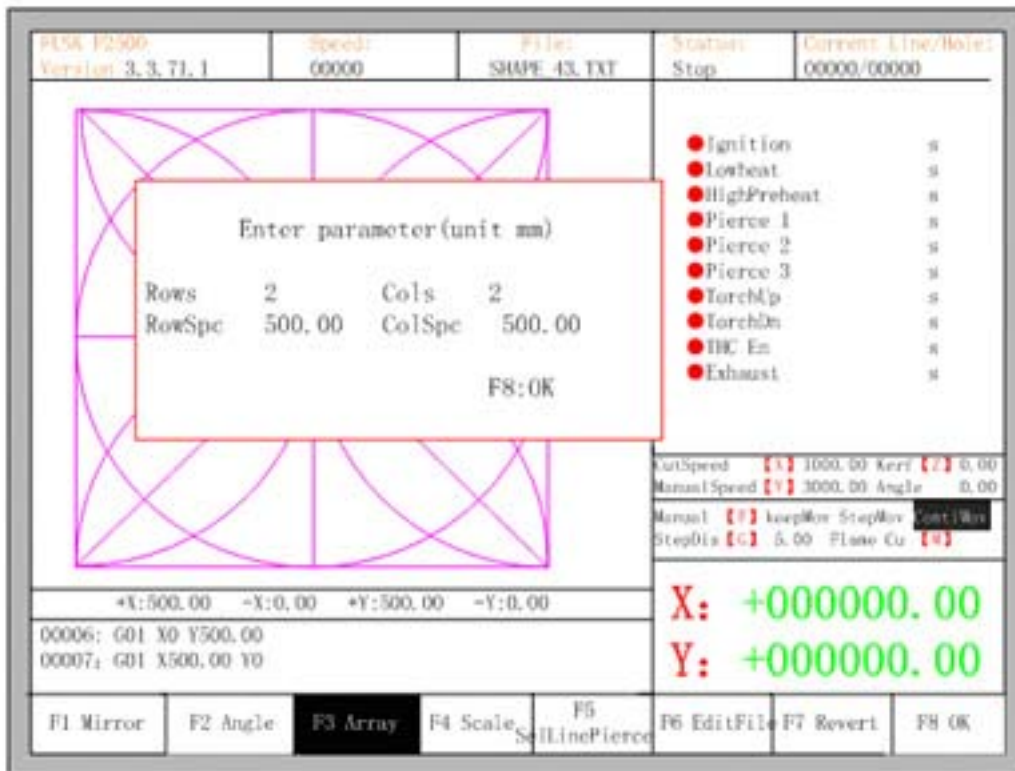

Fig 4.4 arrange in matrix

The result is shown in fig 4.5

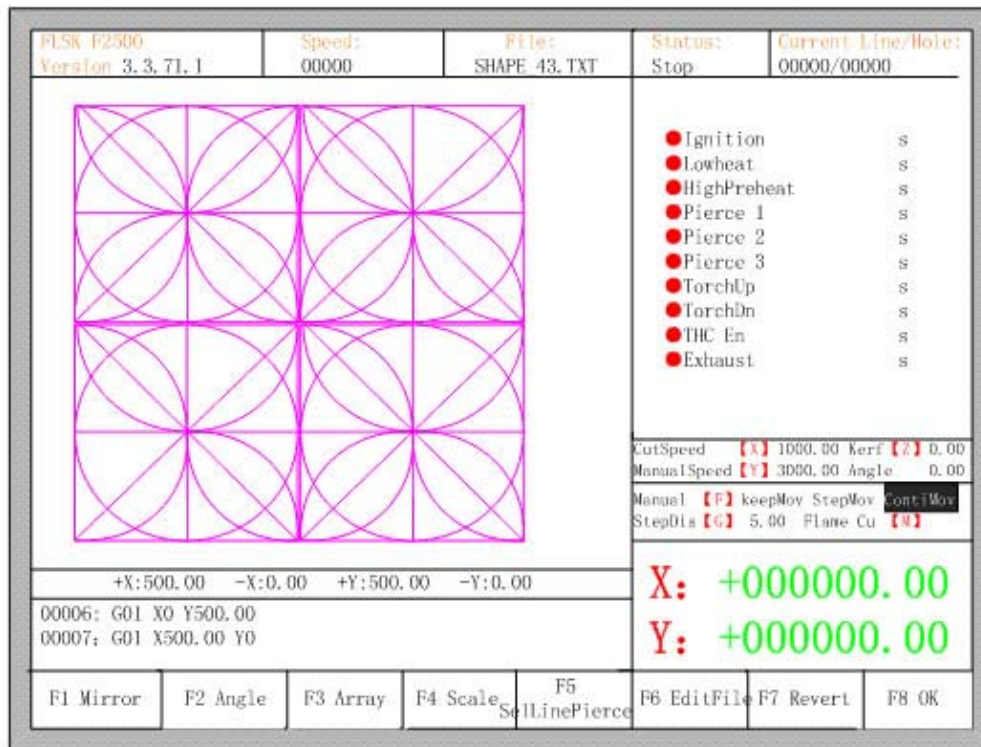

Fig 4.5 result of arranging in matrix

Press [F2] to enter staggered arrangement:

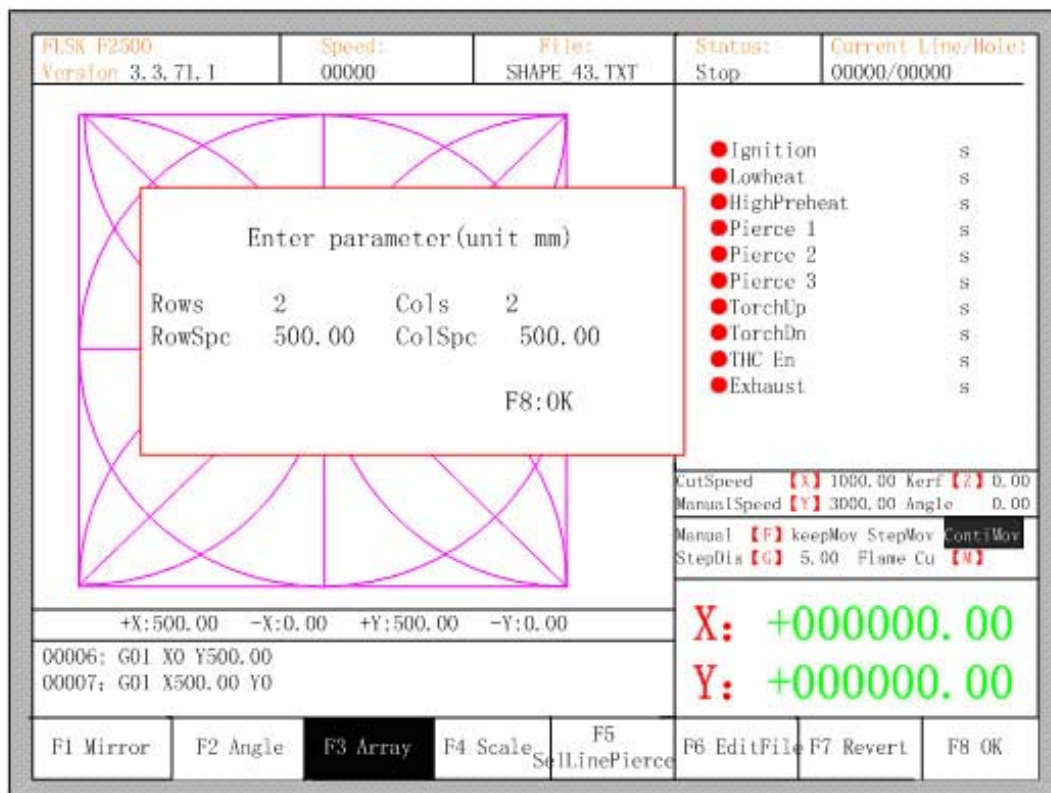

Fig 4.6 staggered arrange

The result is shown in figure 4.7:

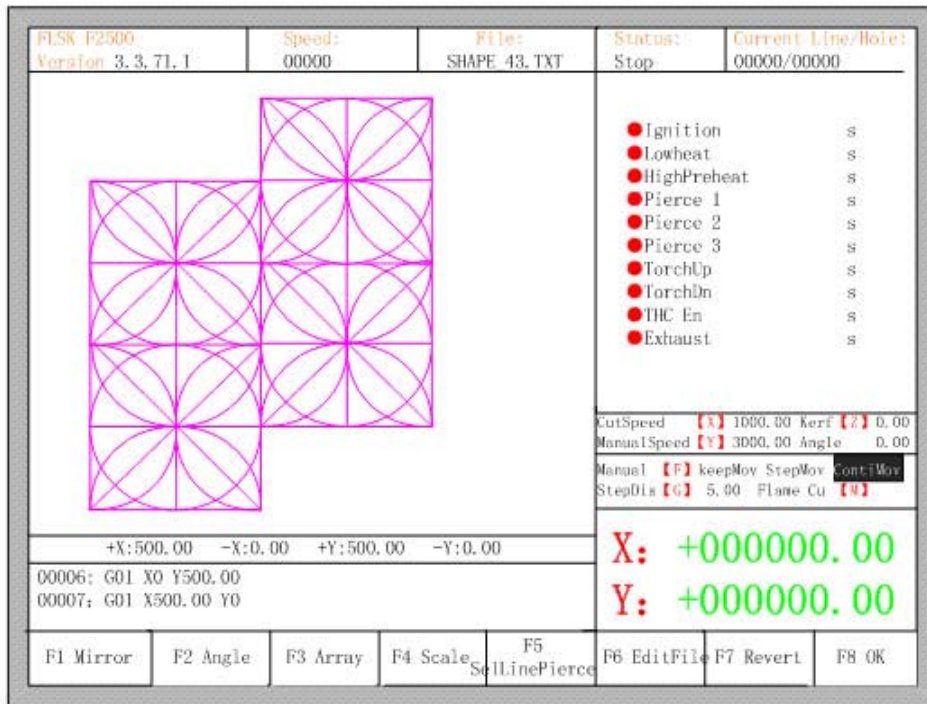

Fig 4.7 result of staggered arrangement

Press [F3] to enter arrangement in stack:

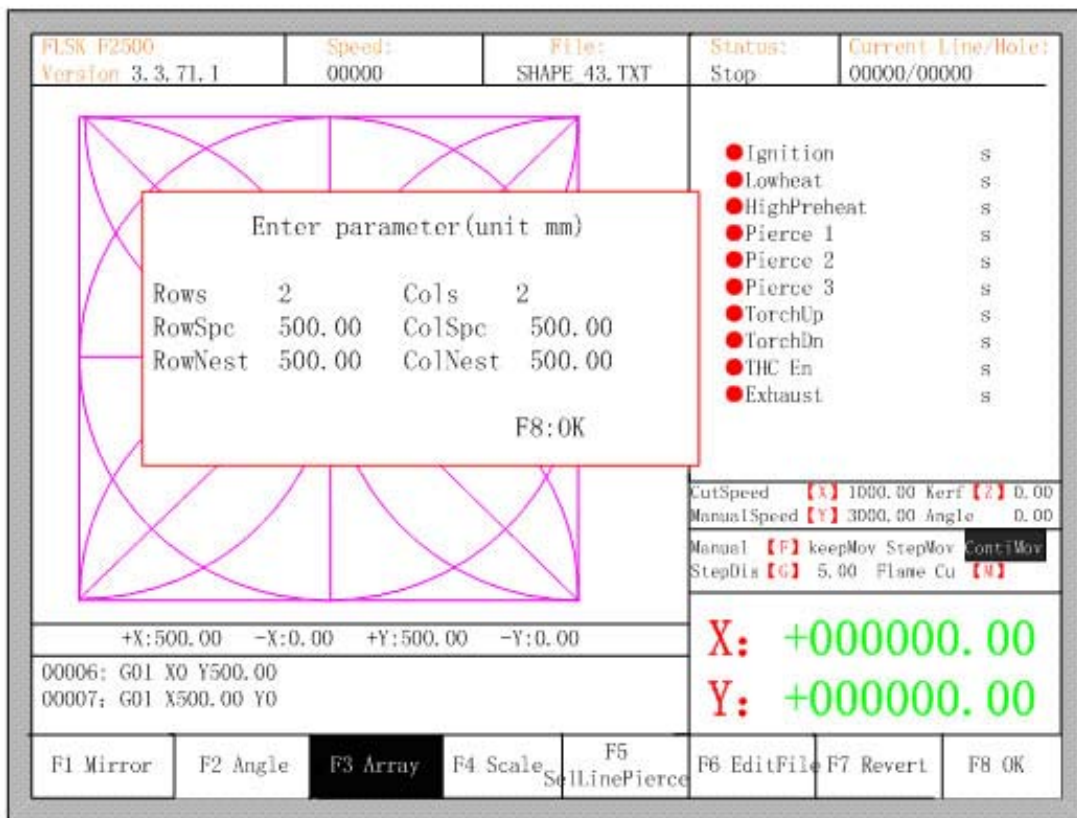

Fig 4.8 arrange in Nest

The result is shown in figure 4.9:

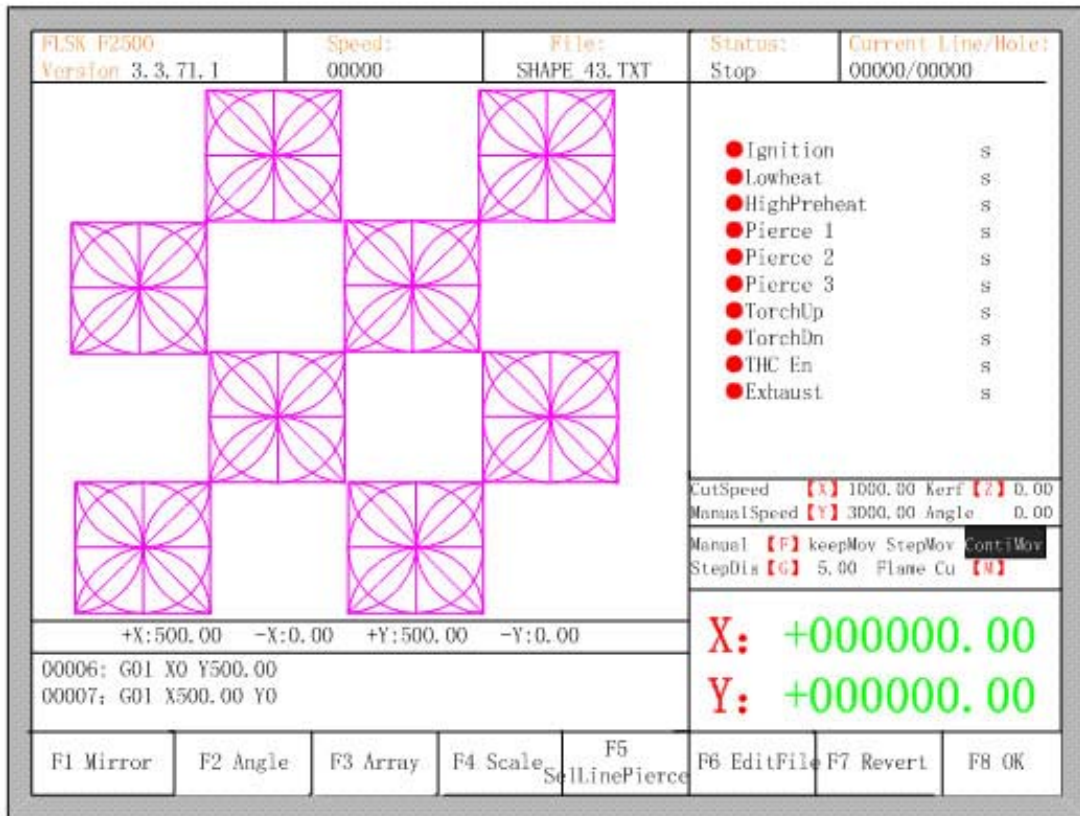

Fig 4.9 result of arrangement in nest

4.4 Zoom in/out

In the part options menu, press [F4] (zoom in/out), the system prompt as figure 4.10:

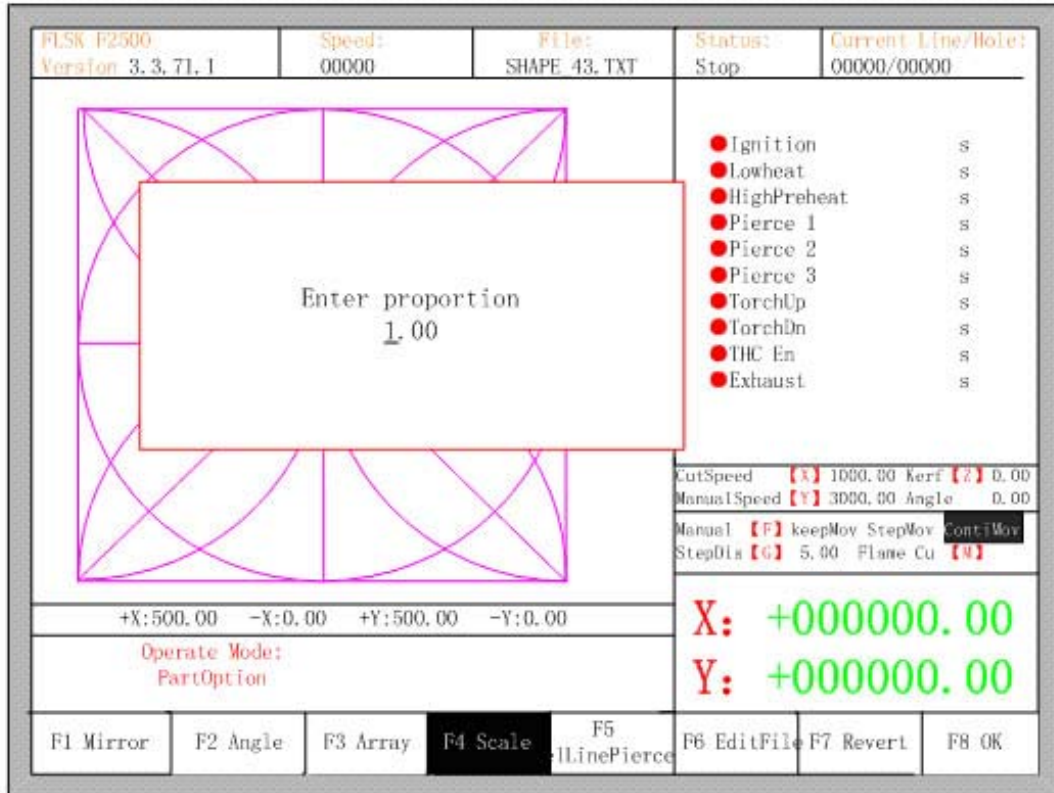

Fig 4.10 set scale

After entering the scale, press [Enter], then the system will automatically zoom in or zoom out the graphic when the parameter is checked to be correct.

4.5 Select row/number

In part options menu, press [F5] to enter selecting row/number, the system will prompt:

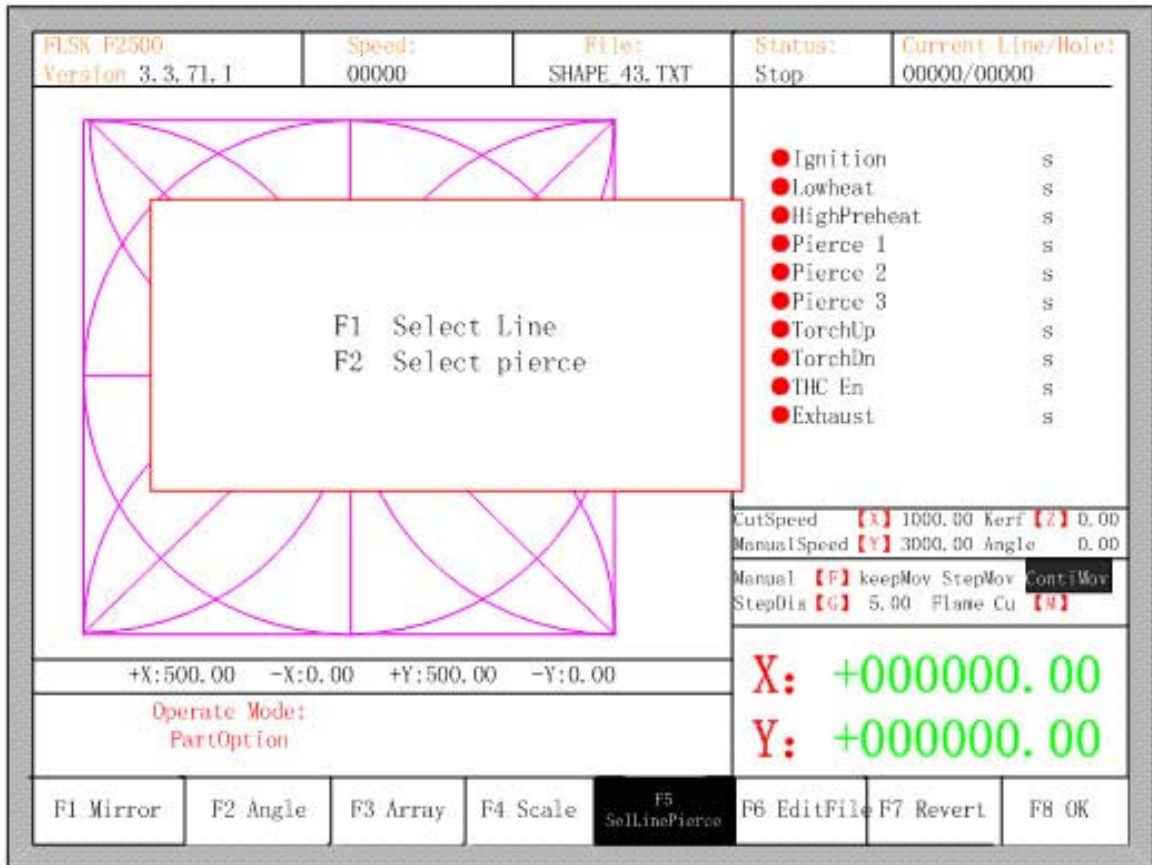

Fig 4.11 select Line/Pierce

4.5.1 Select row

Press [F1] to select the number of row to start cutting with, the system prompts:

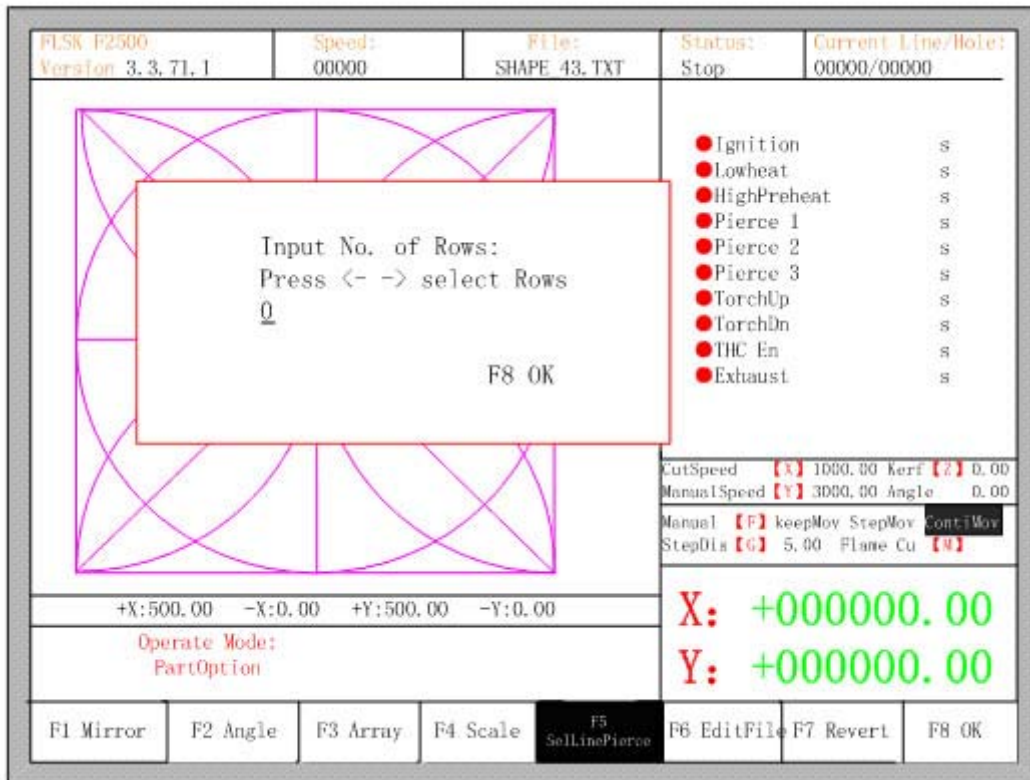

Fig 4.12 prompt to select row

Here , you can directly enter the row number or press ENTER to enter the interface and press ←or→to select row.

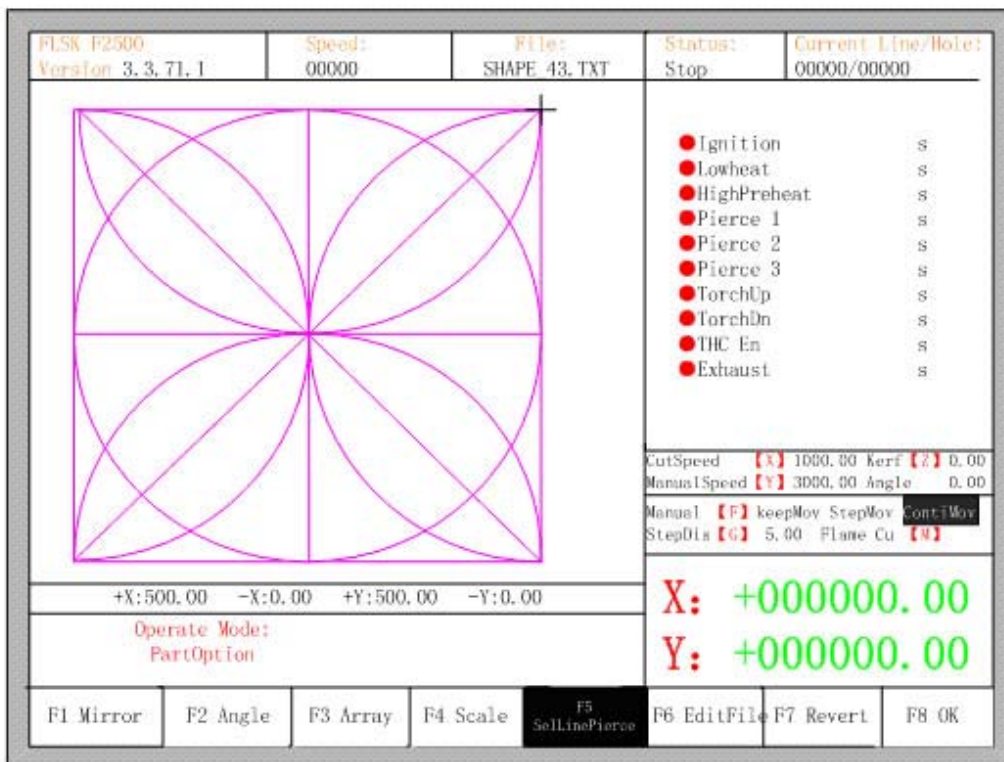

Fig 4.13 select row

After selecting row, press F8 to confirm.

4.5.2 select number

The operation is similar to the choosing row operation.

4.5.3 operation after select row/number

After selecting row or number, press F8 continuously to exit to the main interface. Press SPACE to enter the cutting interface, there are two kind of operation:

1 move from current position to the new position and then cutting

- Press F1 in the cutting interface, the system will directly run to the position of the selected row or number without cutting, then pause and wait for the next operation.

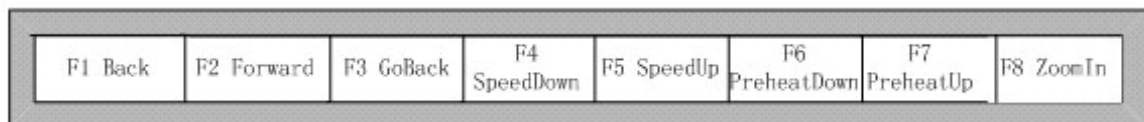

- Press START in the cutting interface, the system will prompt:

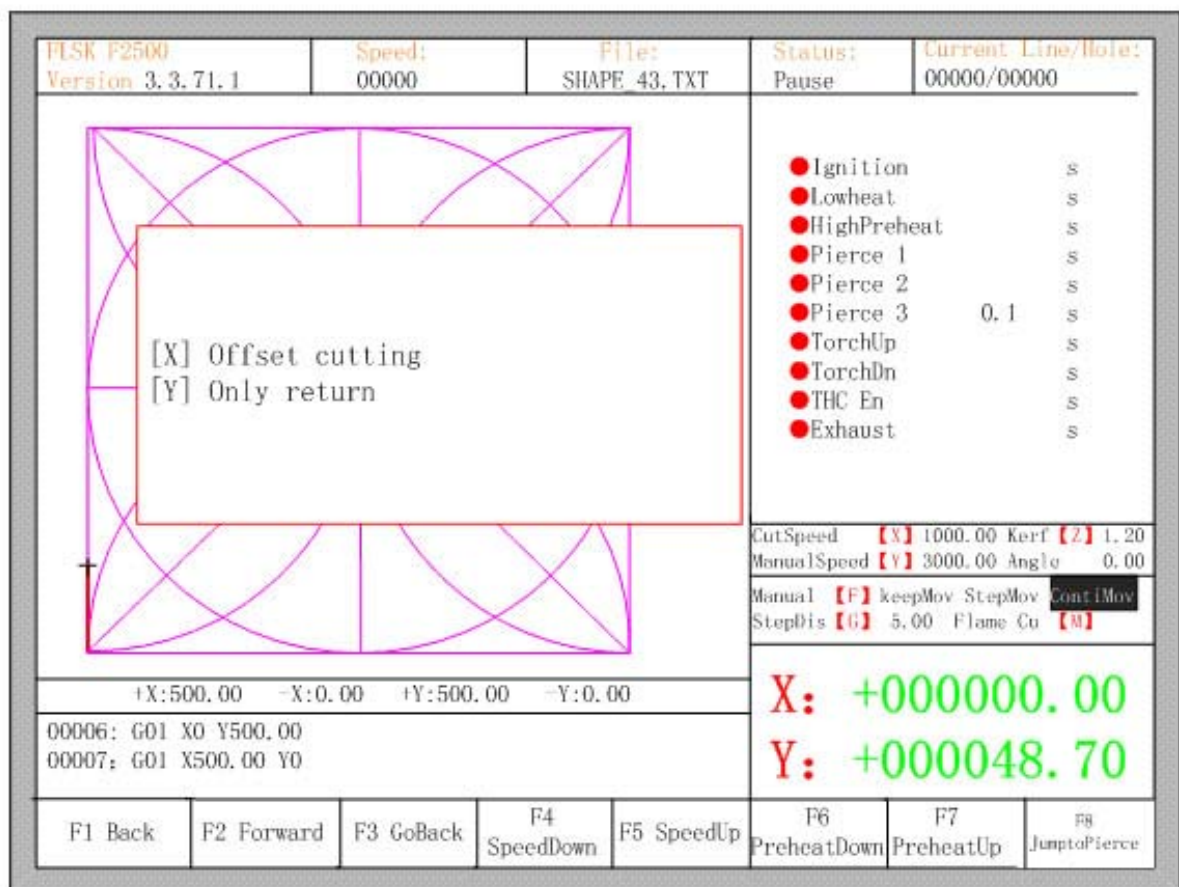

Fig 4.14 operation after selecting row/number

Press Y , the system will also directly move to the selected row and number, then pause and wait for the next operation.

2 Cutting from the current position

After the prompt of Fig 4.14, press X, then the system will start cutting from current position.

4.6 Restore

If you want to cancel all of operations with graphics including mirror, rotation, adjust, scale and array, press [F7] in the part options menu, the system automatically revert to original state of the graphics.

CHAPTER 5 MANUAL FUNCTION

In the automatic interface, press **【F7】**(Manual) to enter manual function interface, shown as Fig 5.1:

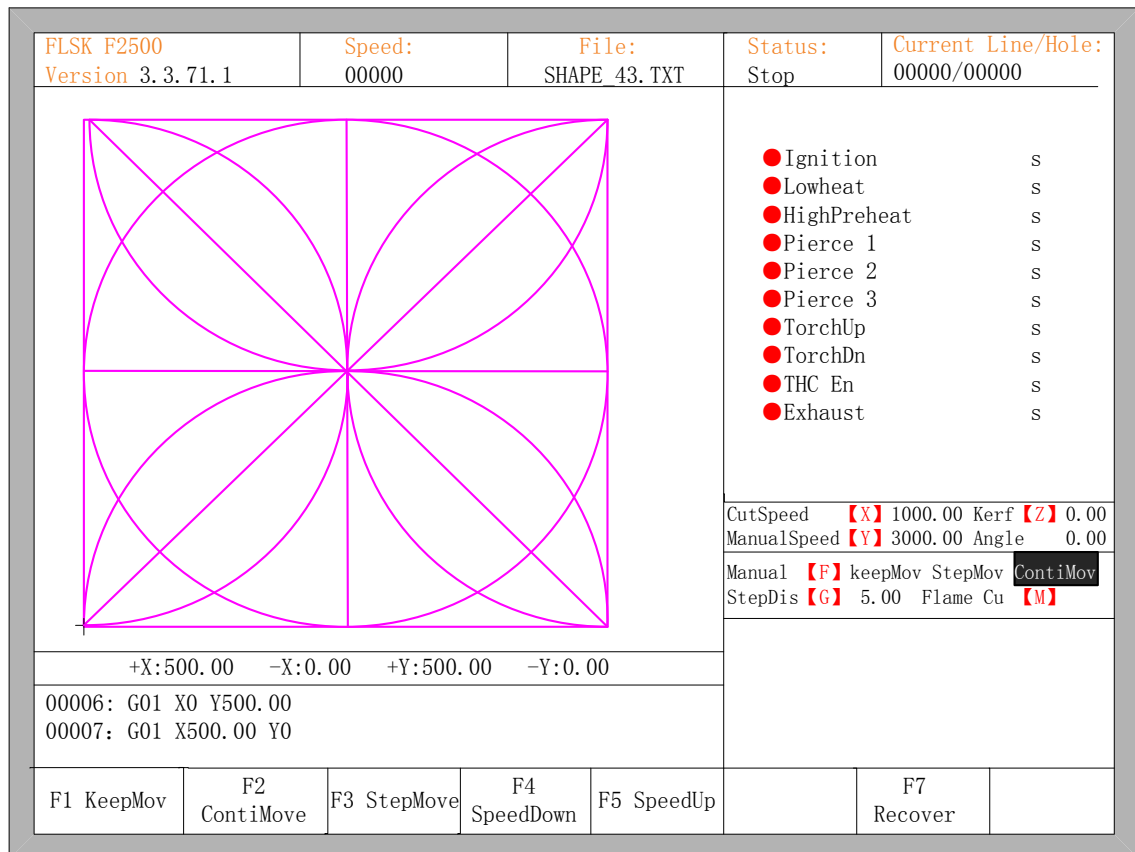

Fig 5.1 manual function interface

The speed in the manual status is controlled by the manual moving parameters. During the process of fixed moving function, you can adjust speed by acceleration or deceleration key. In the manual interface, press numeric key, the cutting speed changes to ratio which is 10 times of the corresponding figure of the speed limit you have set, for example press **【3】**, change the cutting speed to 30% of the speed limit you have set, press **【8】**, change the cutting speed to 80% of the speed limit you have set.

5.1 Fixed Moving Function

When you enter into the manual interface, the default option is continuous moving function. Press key **【F1】** to go for the fixed moving function. At this moment, the system will move toward the specified direction if any directory key is pressed, and when the directory key is released, the system will stop.

5.2 Continuous Moving Function

When in the manual interface, press F2 to enter the continuous-moving function interface. At this moment, the system will move toward the specified direction if any directory key is pressed and then released, and when the directory key or stop key is pressed the system will stop.

5.3 Fixed-length moving

In the manual interface, press F3 to enter the interface of fixed-length moving. The system prompts to input the fixed length:

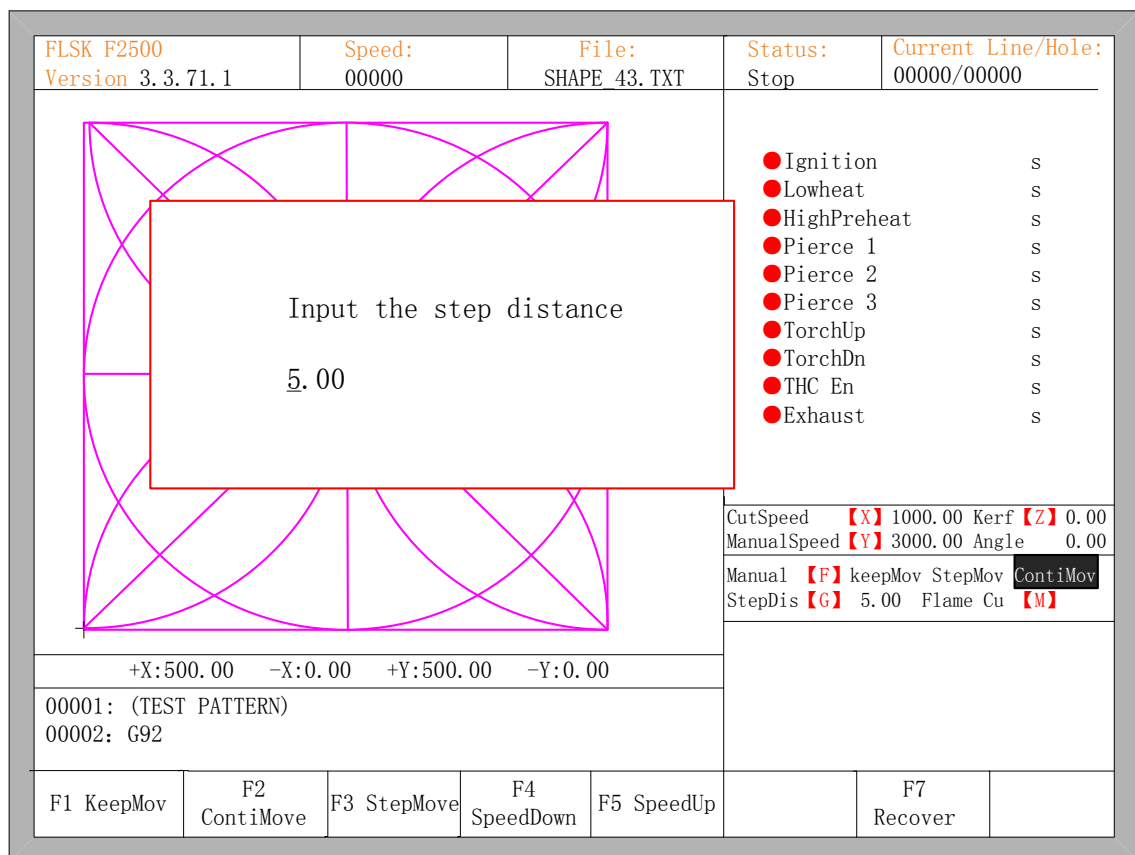

Fig 5.2 Input the fixed length

After inputting the fixed length, press ENTER. Press any direction key and then release, the system will move the fixed length toward the direction, in the process of moving, when any direction key or stop key is pressed, the system will stop moving.

5.4 Breakpoint Recovery

To guarantee that the breakpoint could work correctly, you need to satisfy the following conditions:

1. When the system is paused, the system will automatically regard the paused point as the current breakpoint and remember it.

2. When the system is in the process of incising, the breakpoint signal is connected with the urgent alarm input, when power is off, the system will regard the power-off point as the breakpoint and remember it.

When you need to process after the breakpoint, after the system powers on, don't move the torch, press F7 in the main interface to enter the manual function interface, then press F7 to recover the breakpoint. After recovering it, if the torch hadn't been moved and is on the position when the power is off, press START keyboard, the system will process directly.

After the breakpoint is recovered, if the position is off from the original one, you could move the torch to the original point manually, or realizing it through choosing rows or numbers. (Please refer to chapter 4.5 Row and number Selection). The method is : choose stopping incising, move the torch to the original point manually, choose the nearest row through choosing the row selection(or number selection), press "START", then the system will show in Fig 5.3:

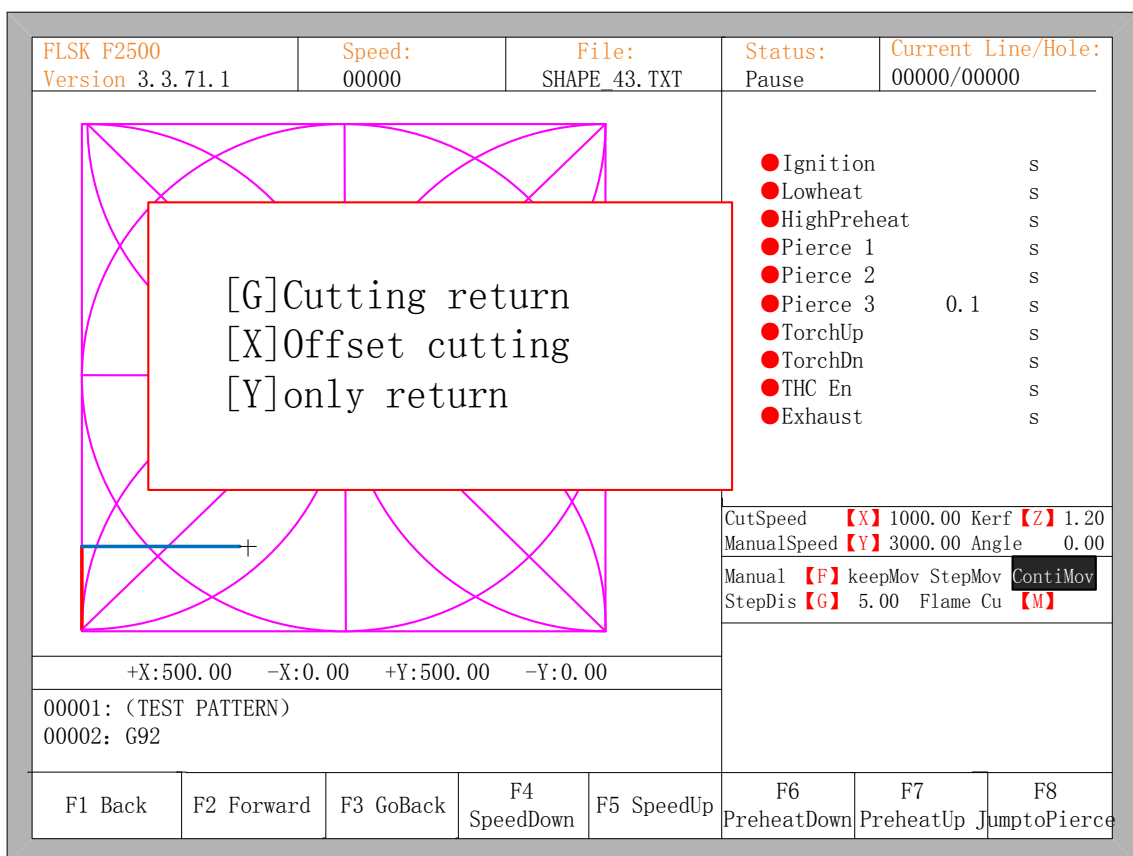

Fig 5.3 restore breakpoint

- Press G, the system will start incising from point which is after moving, and after returning to the position before the torch moves, it will process according to the normal curve.
- Press X, regarding the position after moving as the position before moving, and then process.
- Press Y, move from the position after moving to the position before moving, then wait for the next operation.

Chapter 6 File Operation

The system supports cutting code which has txt and CNC postfix. And the maximum capacity is 1M, the largest number of rows is 10000 lines. You can edit, compile, delete, export internal document, also you can import the file in the U disk into system.

In the main interface, press key **【F2】** (code) to enter local machine code interface, shown as follows:

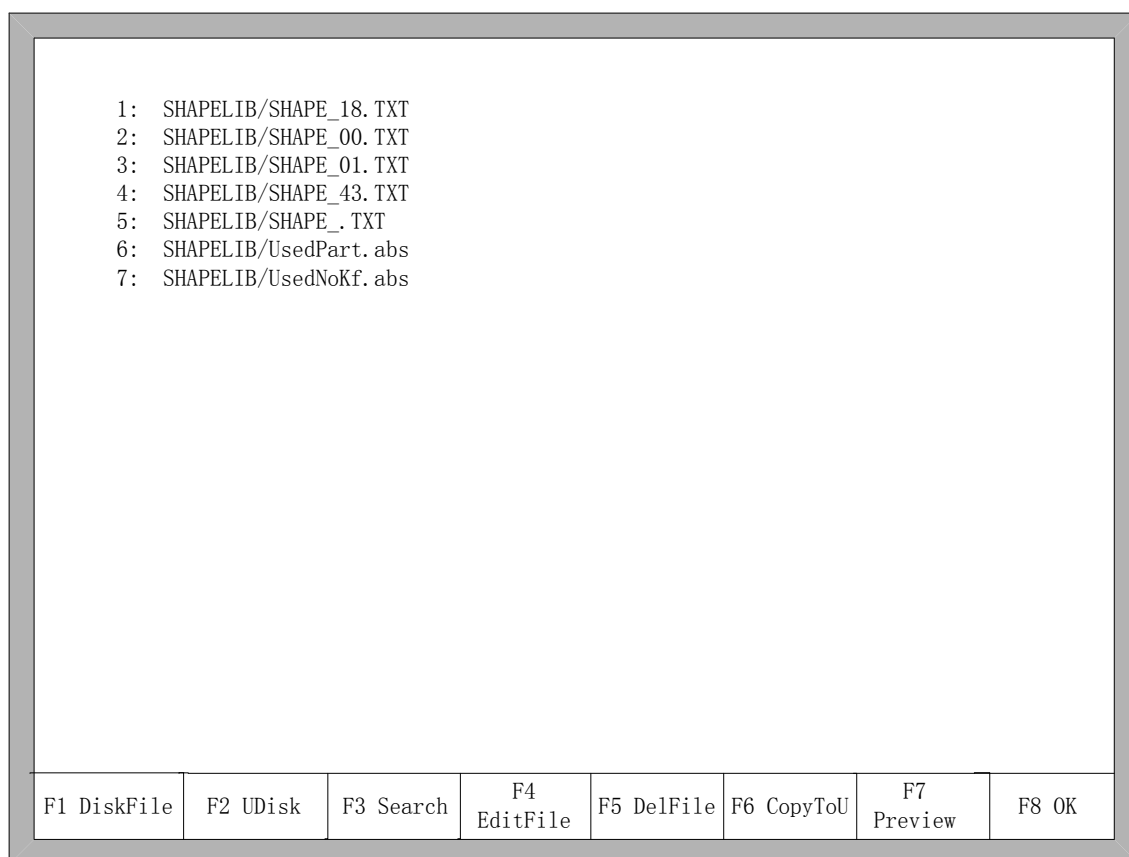

Fig 6.1 code interface

6.1 Files in the Hard Disk

In the file manage interface, press F1 to enter the hardware file list, as shown in Fig 6.1 the system only lists the folder, TXT file and CNC file.

- Press F4, if the current position of the cursor is txt file or cnc file, you could edit them. Please refer to chapter 6.5 on how to edit files.
- Press F5, if the current position of the cursor is txt file or cnc file, you could delete them.
- Press F6, if the current position of the cursor is txt file or cnc file, you could copy the current file to the flash disk when it is connected to the USB interface.
- Press F7, if the current position of the cursor is txt file or cnc file, you could preview the

current graphic.

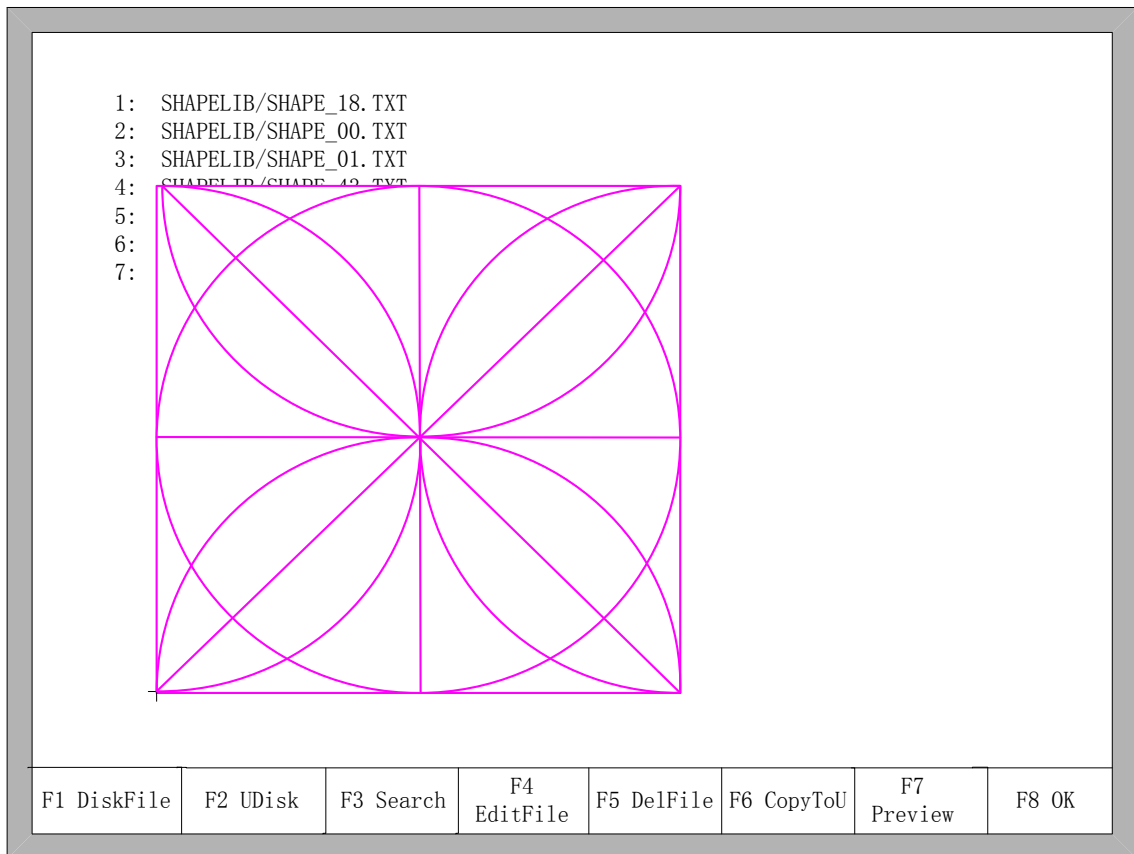

Fig 6.2 Graphic preview

- Press F8, if the current position of the cursor is txt file or cnc file, you could import the current file to the system, after importing, the system will return to the main interface.

6.2 Files in the U Disk

In the code interface, press key **【F2】** to go for U Disk interface.

In the U Disk interface, choose the corresponding cutting code, press **【F6】**, the system will save this code into the internal documents.

Notices: When you open a file on U disk, you must save it as the local machine code before you start cutting. When saved the U disk documents, file name automatically memory, shown as Fig 6.3:

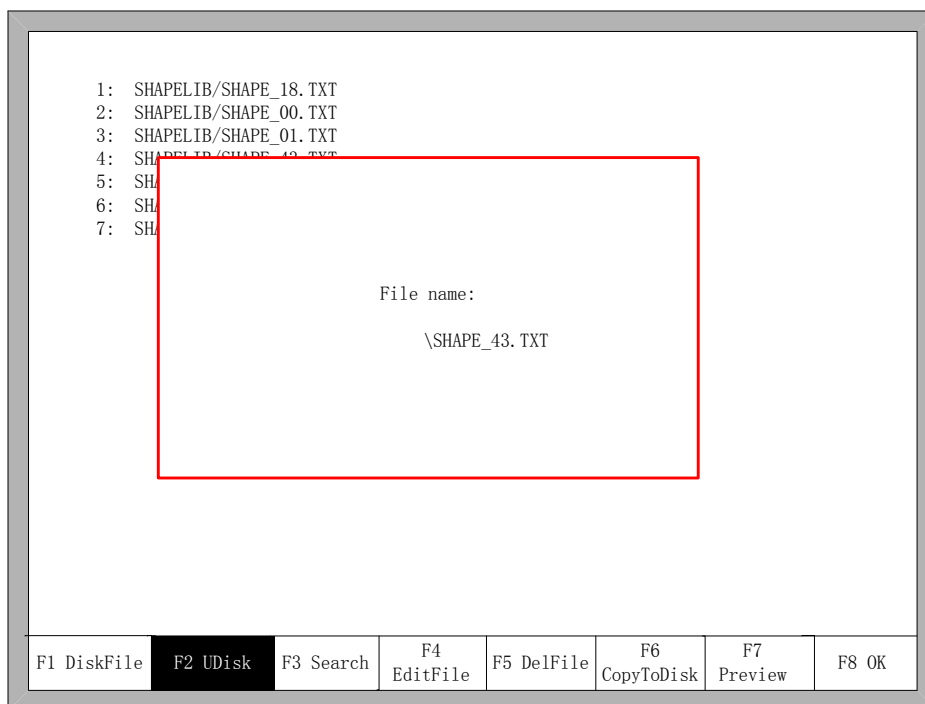

Fig 6.3 save U disk files

When input file name, if you do not want to change the file name, you can be directly press **【Enter】** to preserved; or modify the file name and then press **【Enter】** to save. If the same named file has already existed, the system prompts:

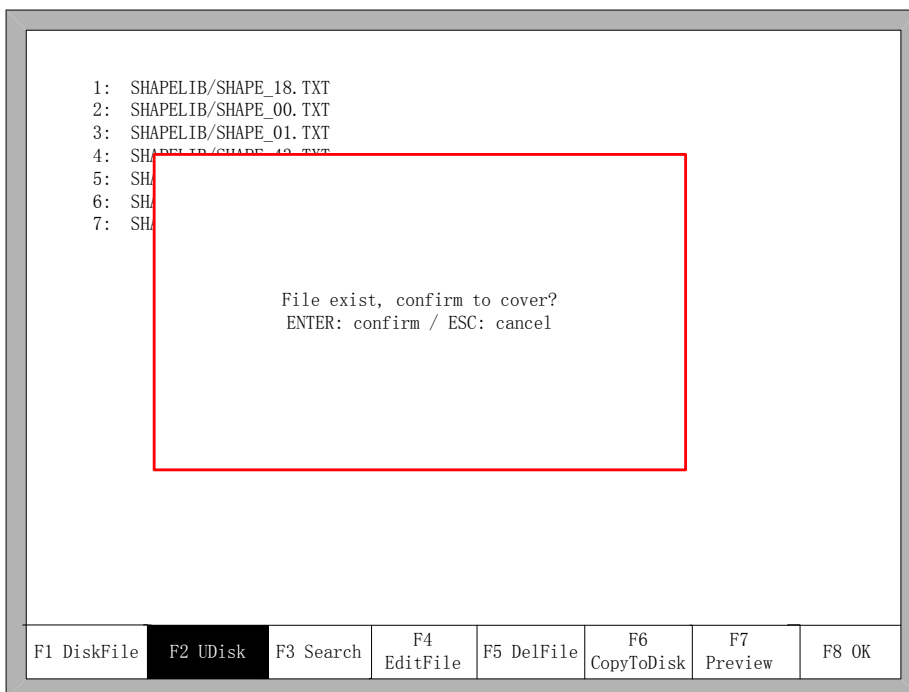

Fig 6.4 Replacement documents

If you want to replace the internal documents, press **【Enter】** key, if you want to change the file name, press **【Esc】**, change the file name and then save.

6.3 Search File

In the file manage interface, press key **【F3】** to search a file. You can input all or part of the file name, then press **【Enter】**, and the system will list all the files that include the input word or file name.

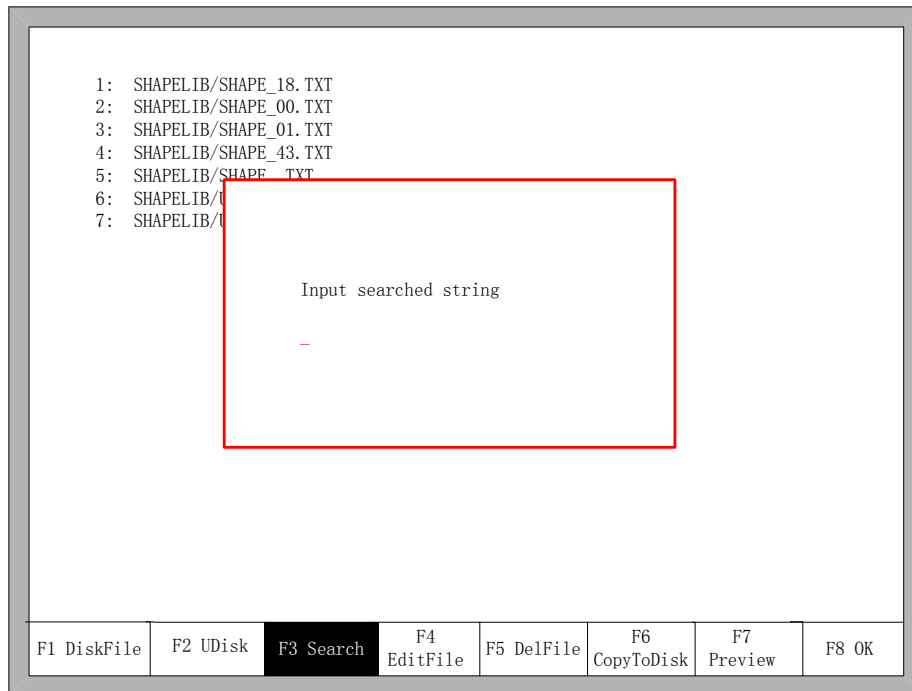

Fig 6.5 search file

6.4 Edit Code

In the local machine code interface, move the cursor to the file that you want to edit, then press **【F4】** to enter the edit interface.

When enter the characters, some keys are reuse keys. Press these keys directly, enter the characters under the button. If first press **【Shift】** key, release the **【Shift】** key and then press Shift Multiplexing button, then enter characters on the button. Or press both **【Shift】** and reuse keys, then enter characters on the button.

When editing the code, press **【F2】** can insert a new line after the current line, and press **【F3】** to delete the current line. Press **【F + Home】** key, the cursor automatically moved to the first character of the current editing line, press the **【F-End】**, the cursor automatically moved to last character of the current line.

Each edit line supports 128 characters maximum.

When you open a file on U disk or new a code file, you must save it as the local machine code before you start cutting. Otherwise, you cannot make use of the breakpoint recovery function or power off protection function.

After edit the code, press **【F8】** to save the code.

6.5 New Code

In the editing code interface (reference 6.4 edit code), you can press key **【F4】** to create a new file to input your own code, shown as Fig 6.5.



Fig 6.6 new code

6.6 Compile Code

After create a new code or edit the code, if you want to know the code is valid or not , in the edit interface, press **【F1】** ,you can compile code to check whether the code is correct.

Chapter 7 Parameter Setting

In the main interface, you can get the parameter interface by pressing key **【F3】** (Para). The parameter function interface is showed in Fig 7.1

Cutting speed	500.000	mm/m
Manual move speed	3000.000	mm/m
G00 move speed	1000.000	mm/m
Demo/back speed	2000.000	mm/m
Dust speed	1000.000	mm/m
Kerf value	0.000	mm
Corner speed(1-100)	100.00	% mm/m
Cutting type	Flame	<->
Demo Run Speed	500.00	mm/m

F1 Common	F2 Flame	F3 Plasma	F4 Powder	F5 System	F6 Import	F7 Export	F8 Save
-----------	----------	-----------	-----------	-----------	-----------	-----------	---------

Fig7.1 Parameter Interface

You can set five kinds of parameter in the parameter interface:

- 1) Common parameters: cutting speed, manual move speed, G00 move speed, the size of kerf gap, corner speed, cutting type, edge cut enable, hold preheat.
- 2) Flame parameters: all the parameters used in oxygen gas cutting
- 3) Plasma parameters: all the parameters used in plasma cutting
- 4) Maring parameters: ignition, perforation cycle parameters, dry dusting offset
- 5) System parameters: you can set system pulses, maximum speed limit, motor parameters and soft limit parameters.

7.1 Common parameters

It is the favorite's parameters in Fig7.1.

- **Cutting Speed:** the maximum cutting speed, unit is mm/m.

- **Manual Move Speed:** the moving speed of cutting torch in manual, unit is mm/m.
- **G00 Move Speed:** the cutting torch speed when G00 is executed or the cutting torch go back to the reference or some other occasion, unit is mm/m.
- **Kerf:** According to the cutting gap width, users set Kerf Gap compensation(the value should be half of the cutting gap) to ensure the dimensional precision, the system will generate a new path automatically to make compensation to work piece. Before cutting a work piece, you can modify kerf gap value, once begin to cut, you are not permitted to modify the value.
- **Corner speed:** Plate thickness affect the cutting tip's ac/dc rate when it moving. The angle between the end of a cut-point line's tangential direction and the direction of the tangent line of the beginning of next cutting point, and the thickness of plate determines cutting tip speed at the transition.

If the normal cutting speed is V , angle is α , plate thickness is h , then cutting tip speed in at the time of intersection is V_x

$$V_x = \frac{\alpha h}{50\pi} V$$

Notice: The unit is mm. The max thickness of plate is 100 mm, if more than 100mm also are considered to be 100mm

- **Cutting Type:** There are two cutting types : Oxygen fuel gas and Plasma parameters. You can press **【←】** or **【→】** to switch with them.

7.2 Flame Parameters

The oxygen fuel parameters, in Fig 7.2, control time delay in IO operation, and whether use high adjustment.

Ignition time	0.00	s
Low preheat time	0.00	s
High preheat time	0.00	s
Pierce 1 time	0.00	s
Pierce 2 time	0.00	s
Pierce 3 time	0.10	s
Exhaust time	0.00	s
Torch up time	0.00	s
Torch down time	0.00	s
Pierce up time	0.00	s
Pierce down time	0.00	s
THC enable	No	<->
Hold preheat	Yes	<->
Edge cutting enable	No	<->

F1 Common	F2 Flame	F3 Plasma	F4 Powder	F5 System	F6 Import	F7 Export	F8 Save
-----------	-----------------	-----------	-----------	-----------	-----------	-----------	---------

Fig7.2 Flame Parameters

- **Ignition Time:** the time delay of opening ignition I/O.
- **Low Preheat Time:** The preheating time before perforating the steel plate. Enter any positive number ,unit is s. During the low pressure preheating process, you can prolong the preheating time by pressing “stop” key, then the preheating time will delay until you press the “start” key to start to high pressure preheat delay.
- **High Preheat Time:** Like **Low Preheat Time** except open different IO.
- **Pierce 1 time:** Perforation time with low pressure fuel gas. Enter any positive number ,unit is s.
- **Pierce 2 time:** Perforation time with middle pressure fuel gas. Enter any positive number ,unit is s.
- **Pierce 3 time:** Perforation time with high pressure fuel gas. Enter any positive number ,unit is s.
- **Exhaust Time:** The delay of turned off oxygen gas to open the exhaust. Enter any positive number ,unit is s.
- **Torch Up Time:** When oxygen gas is turned off, the time for the torch to lift up. Enter any positive number ,unit is s.
- **Torch Down Time:** When oxygen gas is turned off , the time for the torch to put down. Enter any positive number ,unit is s.
- **Pierce Up Time:** Time for the torch to lift up during perforating. The difference between **Torch Up Time** and **Pierce Up Time** is that: **Torch Up Time** means the time that the torch needs to lift up when it needs to move to another place after the current

cutting is over; while the **Pierce Up Time** means the time that the torch needs to lift up after preheating in the fixed cycle of perforation.

- **Pierce Down Time:** Time for the torch to put down in the perforation. The difference between **Torch Down Time** and **Pierce Down Time** is that: **Torch Down Time** means the time that the torch needs to put down before preheating; while the **Pierce Down Time** means the time that the torch needs to put down after finishing **Torch Up Time** and opening cutting oxygen in the fixed cycle of perforation.
- **THC Adjustment:** According to the user device configuration, choose whether or not to use high adjustment box.

7.3 Plasma Parameters

As shown in the fig 7.3, these are Plasma Parameters, which are related with the precision of transmission shaft of the machine.

Arc time	0.00	s
Pierce time	0.00	s
Torch up time	0.00	s
Arcing check time	0.00	s
Position check time	0.00	s
Position up time	0.00	s
Close arc	0.00	mmpm%
Distance to close Arc	0.00	mm
Lose arc delay	0.00	s
Watch arc enable	No	<->

F1 Common	F2 Flame	F3 Plasma	F4 Powder	F5 System	F6 Import	F7 Export	F8 Save
-----------	----------	------------------	-----------	-----------	-----------	-----------	---------

Fig 7.3 plasma parameters

- **Arc time:** Before the arc starting, the system time to wait. At this point, all output I/O are turned off. Enter any positive number ,unit is s.
- **Pierce time:** Perforation time. Enter any positive number ,unit is s.
- **Torch Up Time:** When arc press is turned off, the time for the torch to lift up. Enter any positive number, unit is s.
- **Arcing Check Time:** Enter any positive number, unit is s. If not detected any feedback signal of success arc starting within the detection time, the system prompts an error

message and terminates the current work of cutting, according memory breakpoints to withdraw from the program.

- **Position check Time:** Enter any positive number, unit is s. Delay time of the success of position check.
- **Position up Time:** Enter any positive number, unit is s. Before positioning check, the time for the torch to lift up.
- **Close arc:** In setting the rate of X%, open the output port, close the arc press signal, to prevent the steel melting under low-speed cutting tip due to temperature is too high.
- **Distance to close arc:** in the minimum distance of the cutting line of the initial segment or end segment, close the arc voltage increases.
- **Lose arc delay:** detect the delay time of the feedback of the broken arc, if there's still no arc voltage input, the situation is considered to be broken arc. This parameter can effectively avoid the arc broken alert because of the sensitivity of the broken arc detection in the cutting methods with lead, this guarantees the continuousness of the cutting and avoid the interrupt of frequent alert .
- **Watch arc enable:** Real-time detection of arc voltage signal in cutting process.

If setting "yes", in the cutting process, the system detects the real-time arc voltage feedback signal. If do not detect the signal, the system terminates the current work of cutting, according memory breakpoints to withdraw from the program.

If installing a "No", then in the cutting process does not detect arc voltage feedback signal.

7.4 Powder Parameters

As shown in the Fig 7.4, these are Powder Parameters, which are related with the precision of transmission shaft of the machine.

Dust Ignition time	0.00	s
Dust preheat time	0.00	s
Raise Dust Open time	0.00	s
Raise Dust Close time	0.00	s
Dust Up time	0.00	s
Dust Down time	0.00	s
Dust Horizontal Offset	0.00	mm
Dust Vertical Offset	0.00	mm

F1 Common	F2 Flame	F3 Plasma	F4 Powder	F5 System	F6 Import	F7 Export	F8 Save
-----------	----------	-----------	------------------	-----------	-----------	-----------	---------

Fig 7.4 powder parameters

- **Dust Ignition Time:** Enter any positive number, unit is s.
- **Dust Preheat Time:** Enter any positive number, unit is s.
- **Raise Dust Open/ Close Time:** The time of raise dusting port relatively to the powder port. Enter any positive number, unit is s.
- **Dust Up Time:** The time for the torch to lift up.
- **Dust Down Time:** The time for the torch to put down.
- **Dust Horizontal Offset:** The horizontal displacement of powder gun relative to the cutting tip.
- **Dust Vertical Offset:** The Vertical displacement of powder gun relative to the cutting tip.

7.5 System parameters

The system parameters, as showed in Fig 7.5, are related with the precision of transmission shaft of the machine.

Horizontal Axis Pulse	125.000	n/mm
Vertical Axis Pulse	125.000	n/mm
Max cutting speed	2000.000	mmpm
Max G00 speed	6000.000	mmpm
Max Manual speed	3000.000	mmpm
Small arc limit	500.000	mmpm
Flame adjust time	0.40	s
Plasma adjust time	0.30	s
Emergency stop time	0.08	s
Start speed	250.000	mm
Max +X	100000.000	mm
Max +Y	100000.000	mm
Min -X	-100000.000	mm
Min -Y	-100000.000	mm

F1 Common	F2 Flame	F3 Plasma	F4 Powder	F5 System	F6 Import	F7 Export	F8 Save
-----------	----------	-----------	-----------	-----------	-----------	-----------	---------

Fig 7.5 System Parameters

- **Horizontal Axis Pulse:** The number of pulse that system needs to generate when the machine move 1mm towards X axis, maintaining 3 digits at most after decimal point.
- **Vertical Axis Pulse:** The number of pulse that system needs to generate when the machine move 1mm towards Y axis , maintaining 3 digits at most after decimal point.
- **Max Cutting Speed:** the maximum cutting speed, unit is mm./m.
- **Max G00 speed:** the allowable maximum speed when cutting tips idling.
- **Small Arc Limit:** Maximum speed at cutting a small arc.

Small arc definition:

0 mmpm < cutting speed < 2000mmpm	small arc = 5mm
2000 mmpm < cutting speed < 4000mmpm	small arc = 10mm
4000 mmpm < cutting speed < 6000mmpm	small arc = 15mm
6000 mmpm < cutting speed < 8000mmpm	small arc = 20mm
8000 mmpm < cutting speed < 10000mmpm	small arc = 25mm
10000mmpm < cutting speed < 12000mmpm	small arc = 30mm
12000mmpm < cutting speed < 15000mmpm	small arc = 35mm

- **Flame adjust time:** the whole time for the system accelerates from its start speed to the expected cutting speed.
- **Plasma adjust time:** when plasma cutting , from the time the motor starts to the time

when the motor is up to the cutting speed.

- **Emergency STOP Time:** When encounter Emergency Stop input, the time for dropped from the current speed to zero.
- **Start Speed:** the system's speed when it began to start. Generally do not have to start from 0 , motor will allow a start speed.
- **Max Coordinate:** The maximum positive coordinate which the machine can reach horizontally. Its unit is mm(millimeter). If current coordinate exceeds the value, the system will stop running.
- **Min Coordinate:** The minimum negative coordinate which the machine can reach horizontally. Its unit is mm(millimeter). If current coordinate is less than the value, the system will stop running

7.6 Parameter import

In the parameter configuration interface, press F6 to import the parameters. The parameters should satisfy two conditions:

1. The parameters exported from the incising machine control system(refer to 7.7 Parameter Export) should satisfy the specified format. The file format is F2500.DAT
2. The file should be stored under the root folder of flash disk which is connected to the USB interface.

When the above condition is satisfied, in the Fig 7.6, press Enter to confirm, and then you could import the backup parameters to the system.

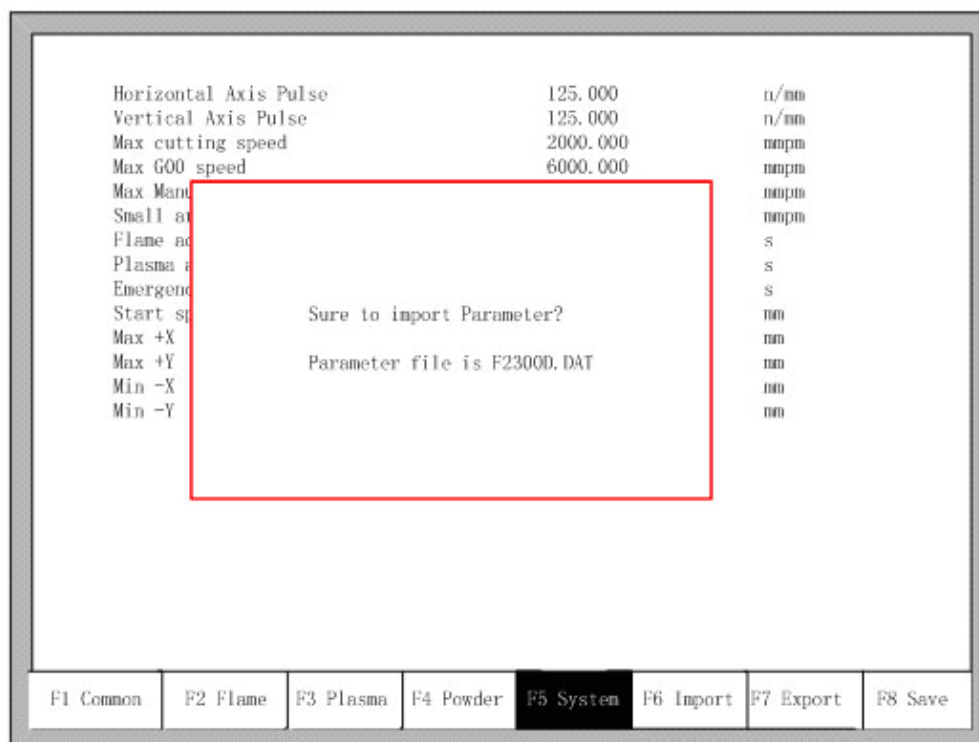

Fig 7.6 Parameter import

7.7 Parameter export

After the parameter configuration is over, press F7 in the parameter configuration interface to export the parameters, you should connect the flash disk to the USB interface before exporting.

In the interface shown in Fig 7.7, after pressing Enter, the parameters will automatically be saved in the root folder of flash disk, the file name is F2500.DAT

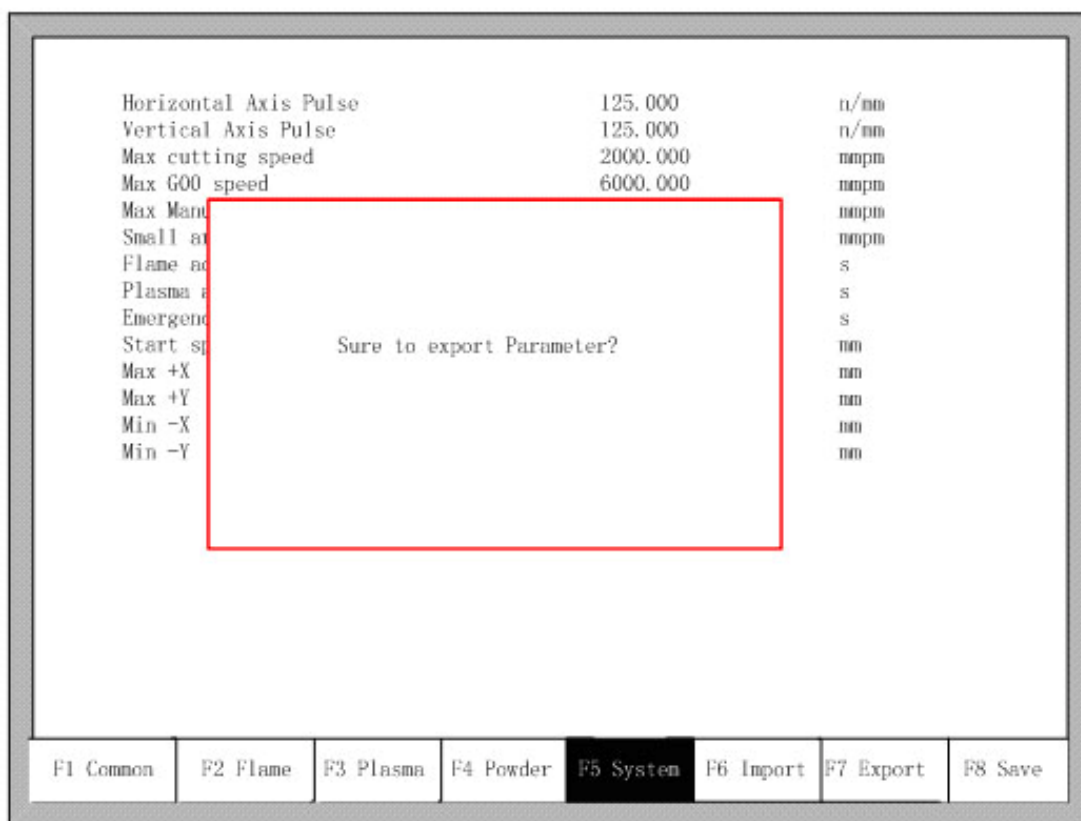

Fig 7.7 Parameter export

7.8 Save parameters

After parameter modification, press **【F8】** to save, shown in Figure 7.8

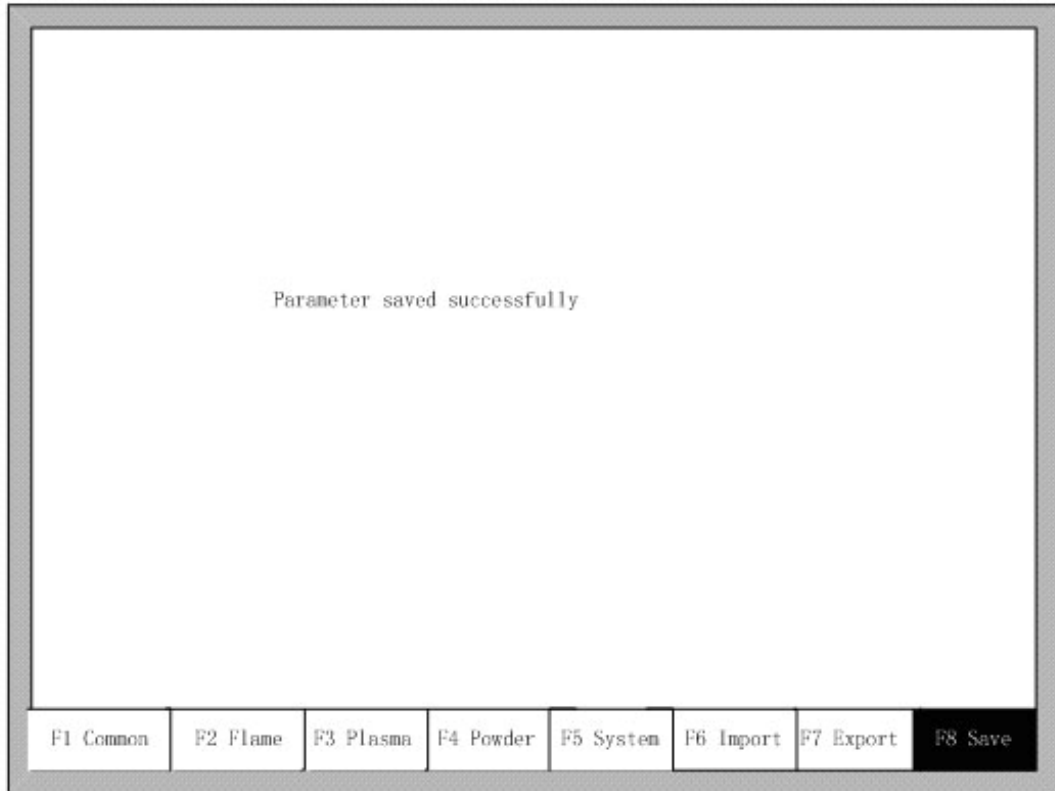

Fig 7.8 System Parameters

Note: when any parameter has been modified, you must take preservation operation to keep modification valid, or the system will take the original parameters.

Chapter 8 Diagnosis Function

input	
Forward limit	●
Back limit	●
Right limit	●
Left limit	●
Emergency stop	●
Arcing feedback	●
Position detect	●
Plasma crash	●
Up move input	●
Down move input	●
Left move input	●
Right move input	●
Acceleration input	●
Deacceleration input	●
Torch up input	●
Torch down input	●

F1 Input	F2 Output			F5 KeyBrd	F6 SelfCheck	F7 DateTime	F8 SystemDef
----------	-----------	--	--	-----------	--------------	-------------	--------------

Fig8.1 Diagnostic interface

You can be diagnosing the I/O and keyboard in the interface.

8.1 Diagnosis interface index

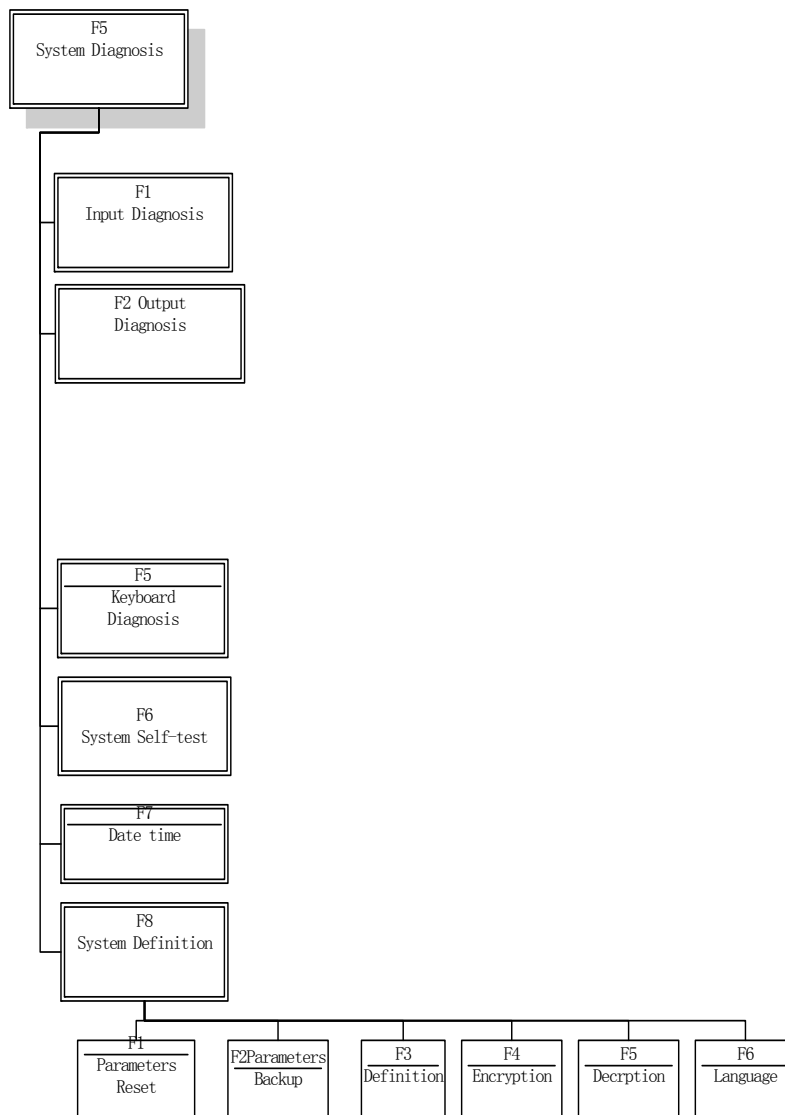

8.2 Input Diagnosis

The system will read current IO information when press **【F1】** (Refresh) to refresh the interface, and display all IO's status. "On" means the input is effective, and "Off" means the input is ineffective.

8.3 output Diagnosis

In diagnosis interface ,press **【F2】** to enter output diagnosis interface, shown as Fig8.2

Output	
Ignition	●
Low preheat	●
High preheat	●
Low Oxygen	●
Medium Oxygen	●
High Oxygen	●
Torch up	●
Torch down	●
exhaust	●
THC enable	●
Position detect	●
Arc starting	●
HoldTorch	●
Dust spray	●
Raise dust	●
Dust preheat	●

F1 Input	F2 Output	F3 OpenOut	F4 CloseOut	F5 KeyBrd	F6 SelfCheck	F7 DataTime	F8 SystemDef
----------	------------------	------------	-------------	-----------	--------------	----------------	-----------------

Fig 8.2 Output diagnosis

Press **【↑】**, **【↓】**, **【←】**, **【→】**, you can move the cursor to the corresponding output port, press **【F3】** to open the corresponding output port, press **【F4】** to close the corresponding output. ● represents the valid output, ○ represents the invalid output.

8.4 Key-press Diagnosis

In the diagnostic interface, a key value will be displayed behind “KEY:”, whenever the key is pressed.

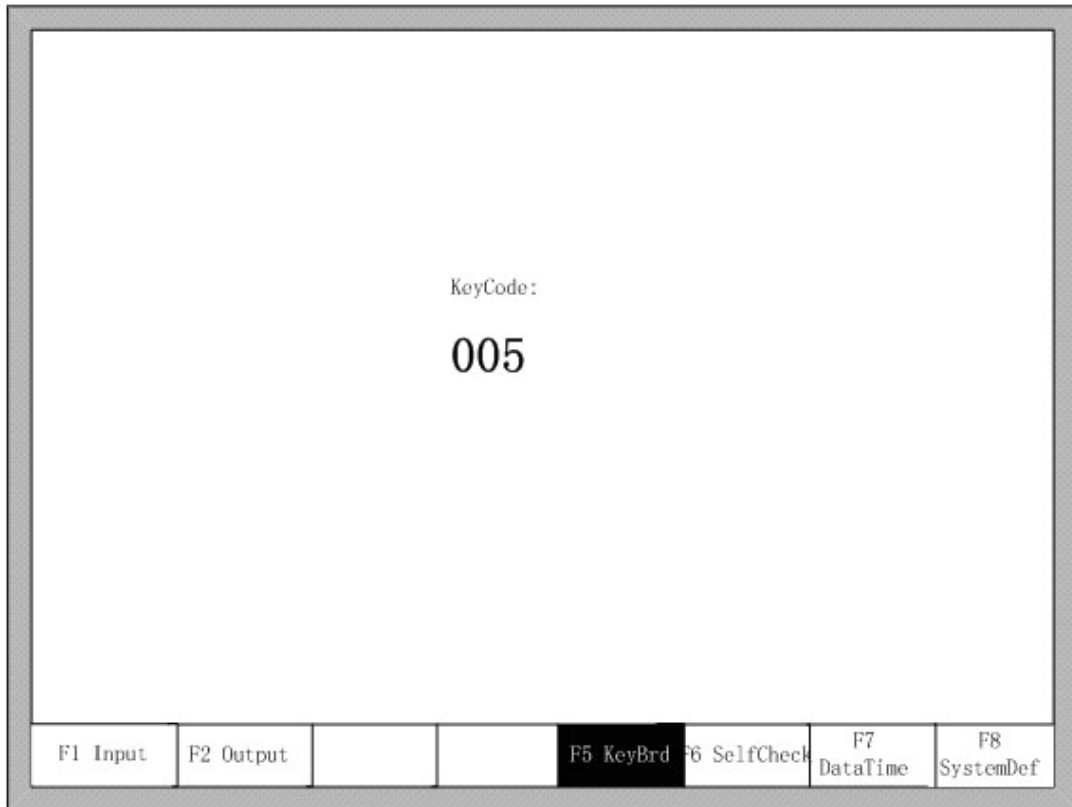

Fig 8.3 Keyboard Diagnosis

8.5 System self-check

In the system diagnosis interface, press F6 to enter the system self-check interface.

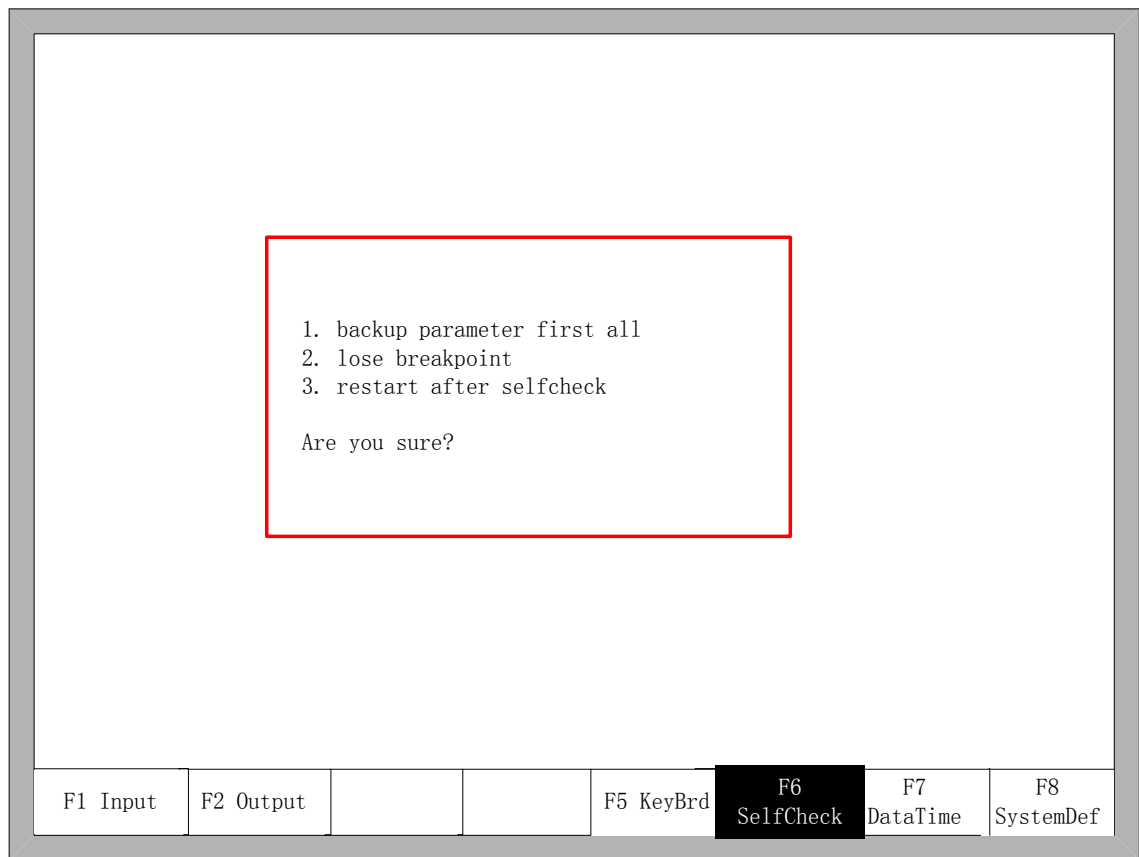

Fig 8.4 System self-check

If the self-check is OK, the system will show:

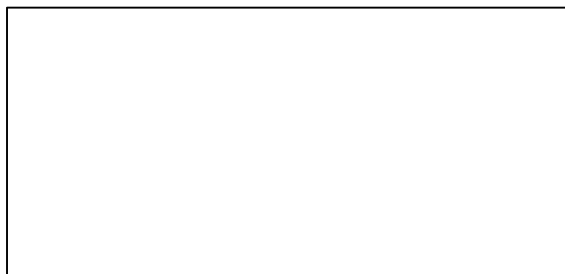

Fig 8.5 Self-check pass

If the self-test is down, there will be the following alarm type:

- DSP Dual ram is error
- ARM Dual RAM is error

When coming across these situations, please power off, reboot after about half minutes. If the situation happened on the machine which has been working for long time, please open the chassis and clean up the dust.

8.6 date and time

Press F7 in the system diagnosis interface to set the date and time

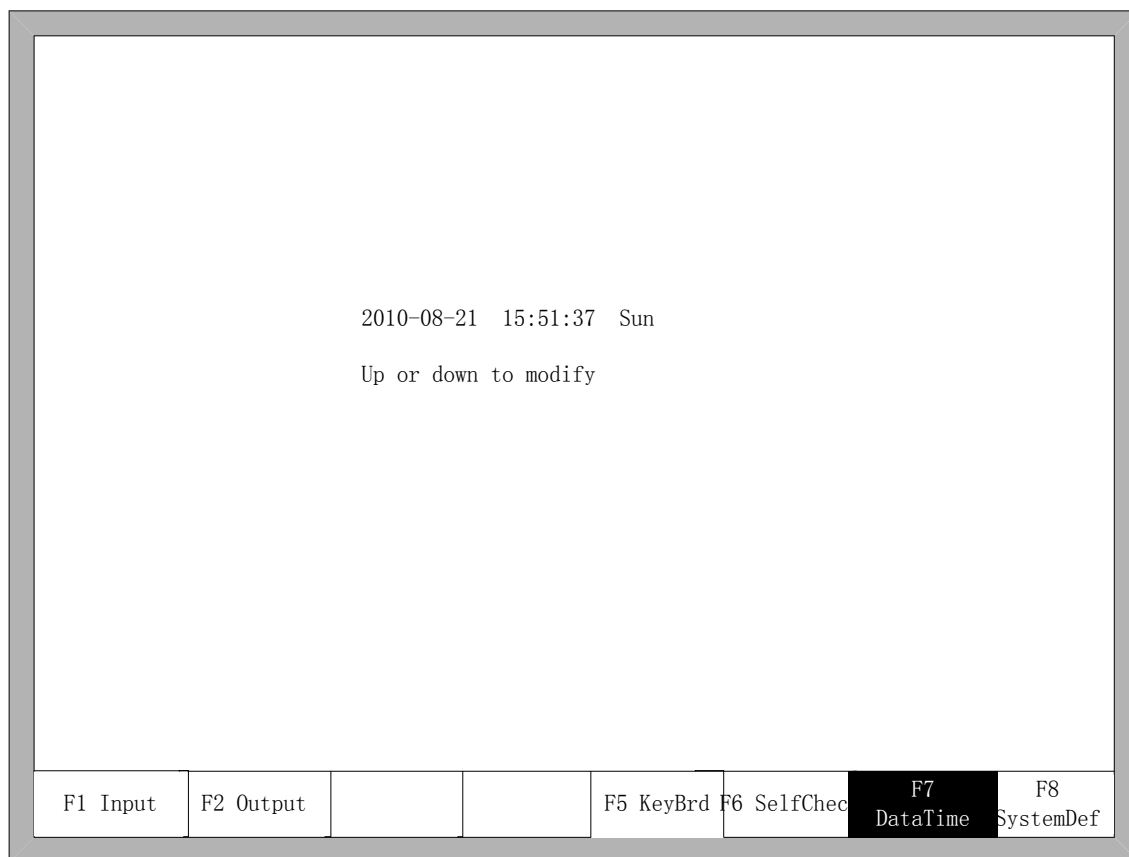

Fig 8.6 System time

Move the cursor to the corresponding date, time or week, press 【↑】或【↓】to adjust the time

8.7 System Definition

In the system diagnosis interface, press F8 to enter the system custom definition interface, in the interface, you could set the input IO, output IO or system coordinate, also reset or backup the parameters and one key switch between English or Chinese.

8.7.1 Parameter backup and restore

Parameter Backup: The process of parameter backup is, in the main interface press F5(System Diagnosis), F8(System Definition), F2(Parameter Backup). The system will need code, after inputting the code “1396”, press Enter, the system will import the default parameters. In the following process, if the parameters is modified or some of them is broken, reset the parameters.

Warning: after adjusting the equipment, please backup the parameters.

Parameter Reset: The process of reset the parameters is, press F5(System Diagnosis) in the main interface, F8(System Definition), F1(Parameter Reset).

Warning: After resetting successfully, please restart the system.

8.7.2 Input definition

The controller could change the IO definition, including changing the order of IO number, the type of IO(normally open or closed) according to the user's need. In the system custom definition interface, press F3 to enter the definition interface, press F1 to enter the input definition interface. As shown in fig 8.7.

Definition of input					
	Port	Type		Port	Type
Forward limit	02	●	Up move input	09	●
Back limit	15	●	Down move input	10	●
Left limit	14	●	Left move input	07	●
Right limit	01	●	Right move input	08	●
Sharpstop	03	●	Acceleration input	16	●
ArcFeedback	04	●	Deacceleration input	17	●
PosFeedback	05	●	Torch up input	18	●
PlasmaCrash	06	●	Torch down input	19	●

Port- Press PgUp/PDn Type-Press Enter

F1 Input	F2 Output	F3 Axes	F4 Motor				F8 Save
----------	-----------	---------	----------	--	--	--	---------

Fig 8.7 input definition

In the interface press **【↑】**、**【↓】**、**【←】**、**【→】**，move the cursor to the position that needs changing, press **【PageUp】** 或 **【PageDown】** to change the number of the Input, press **【Enter】** to change the type of the input.

If the external type of input is normally closed, please set the IO type to ●, if the type is normally open, please set the IO type to ●.

8.7.3 Output definition

The controller could change the IO definition, including changing the order of IO number, the type of IO(normally open or closed) according to the user's need. In the system custom definition interface, press F3 to enter the definition interface, press F1 to enter the input definition interface. As shown in fig 8.8.

Definition of output					
	Port	Type		Port	Type
Ignition	03	●	Exhaust	06	●
LowPreheat	01	●	THC	08	●
HighPreheat	17	●	PosDetect	19	●
LowOxygen	04	●	ArcStart	16	●
MidOxygen	05	●	LowSpdInCorner	18	●
HighOxygen	14	●	Dust spray	07	●
TorchUp	02	●	Raise dust	20	●
TorchDown	15	●	Dust preheat	21	●

Port- Press PgUp/PDn Type-Press Enter

F1 Input	F2 Output	F3 Axes	F4 Motor				F8 Save
----------	------------------	---------	----------	--	--	--	---------

Fig 8.8 output definition

In the interface press **【↑】**、**【↓】**、**【←】**、**【→】**，move the cursor to the position that needs changing, press **【PageUp】** 或 **【PageDown】** to change the number of the Output, press **【Enter】** to change the type of the Output.

The output type is open drain transistor output type.

type ● means that if the output signal is effective, the transistor is on. type ● means that is the output signal is effective, the transistor is off.

8.7.4 Coordinate definition

The system could provide IO definition for the user. As shown in Fig 8.9

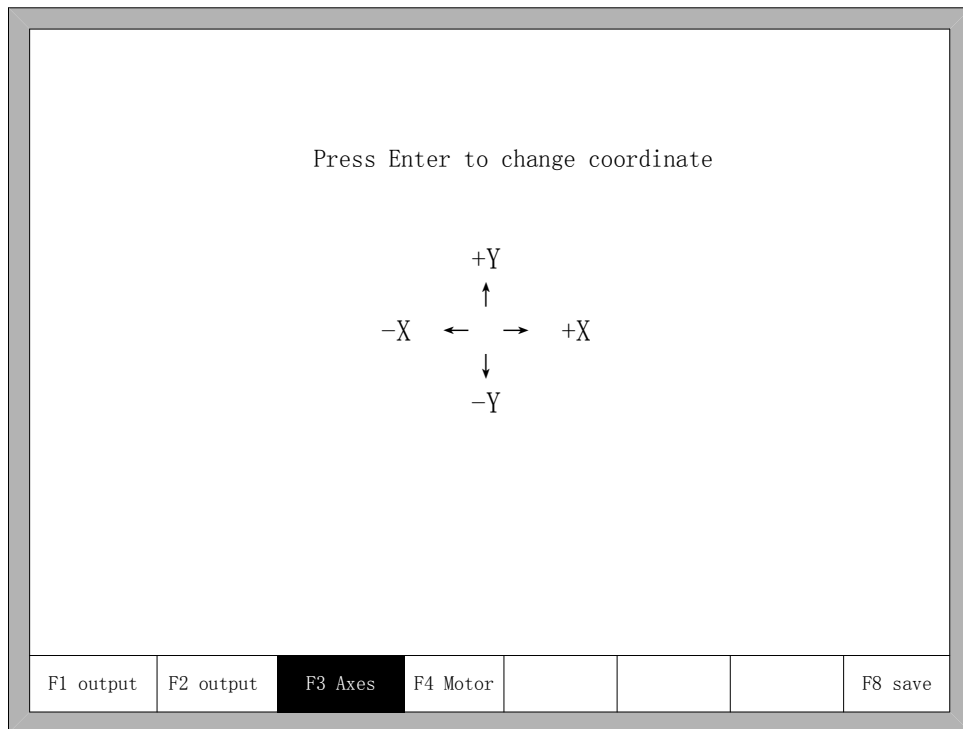

Fig 8.9 Coordinate Definition

In the interface, press Enter repeatedly to change among 8 type of coordinates. Press F8 to save.

Chapter 9 Graph

In the main interface, press **【F1】** (ShapeLib) to enter graph interface, shown as follows:

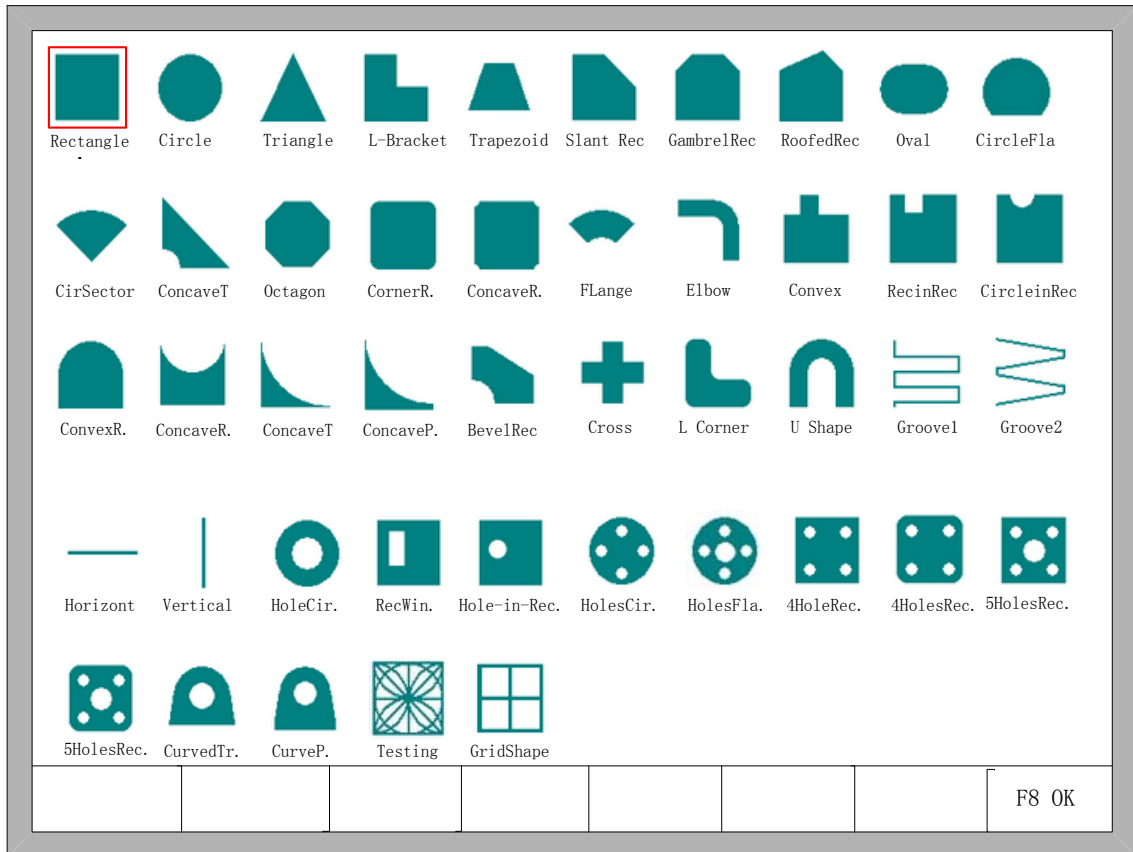

Fig 9.1 first page of graph

You can press **【↑】**, **【↓】**, **【←】**, **【→】** to choose different graph.

9.1 Choose Graph

In home interface of graph, move the cursor to the required graph, press **【F8】** to confirm, shown as Fig 9.2:

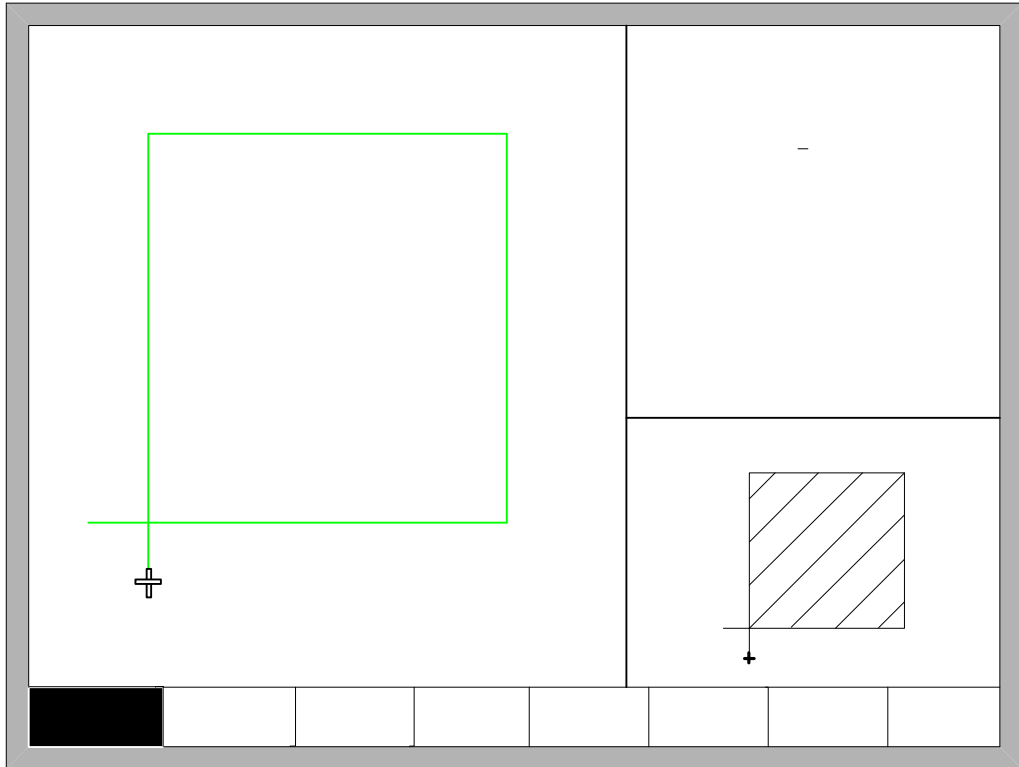

Fig 9.2 Chip size interface

You can press **【↑】**, **【↓】**, **【←】**, **【→】** to modify sizes, after modification , press **【F8】** to confirmed.

Press any key to return to graphics processing interface as shown in Fig3.3.

9.2 Film/Hole Size

In Fig 9.2 interface, you can press **【F2】** to choose hole size, shown as Fig 9.3:

F2
Outside

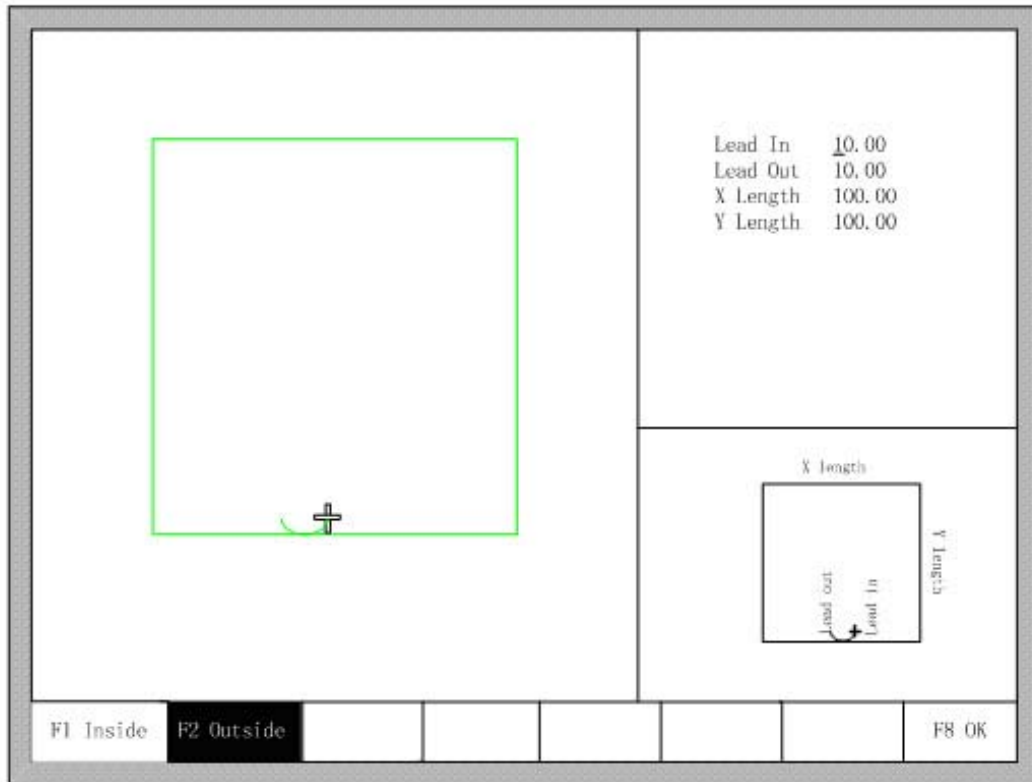

Fig 9.3 hole size

Modify sizes like modify chip sizes.

After modification , press **【F8】** to confirmed.

Press any key to return to graphics processing interface as shown in Fig3.3.

Note:

The following graphics don't have hole sizes:

Straight line groove, Bevel groove, Straight line kerf, Vertical kerf, Hole-in- Rotundity, Rectangle window, Hole-in-Rectangle, Four-holes in Rotundity, Holes in flange, Four-holes in rec, Four-holes in Filleted corner rec, Five-holes in rec, "Five-holes in Filleted corner rec, Curved trapezoid, Curved polygon, Testing Shape, Grid Shape.

Chapter 10 Port Explanation

10.1 Input port

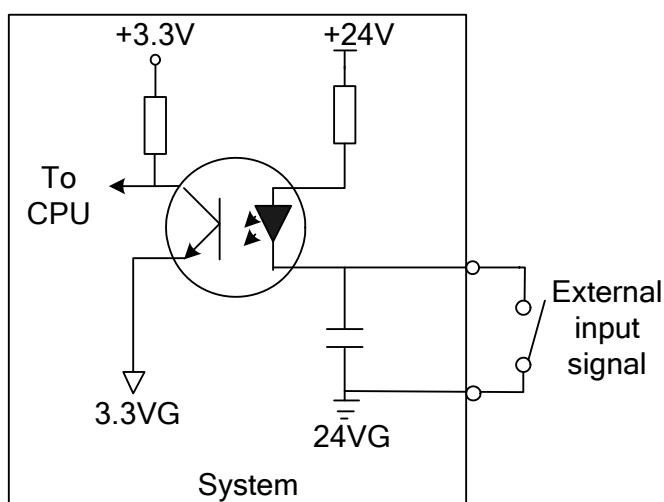

Fig10.1 input port circuit

- Input signal is a mechanical contact switch, normally open type, it is effective when it is connected to 24VG, and it is ineffective when it is float or connected to 24V
- 16 input ports totally
- Input signal definition

Pin number	Signal name	remark
1	X+ limit	X+ stop input, float it if not use, this is horizontal
14	X- limit	X- stop input, float it if not use, this is horizontal
2	Y+ limit	Y+ stop input, float it if not use, this is vertical
15	Y- limit	Y- stop input, float it if not use, this is vertical
3	Emergency stop	Emergency stop input, float if not use
4	Arcing successfully	

5	Positioning successfully	
6	Plasma collision	
7	Move left/C	Remote control input
8	Move right/D	Remote control input

10.1.1 Input Wiring Instructions

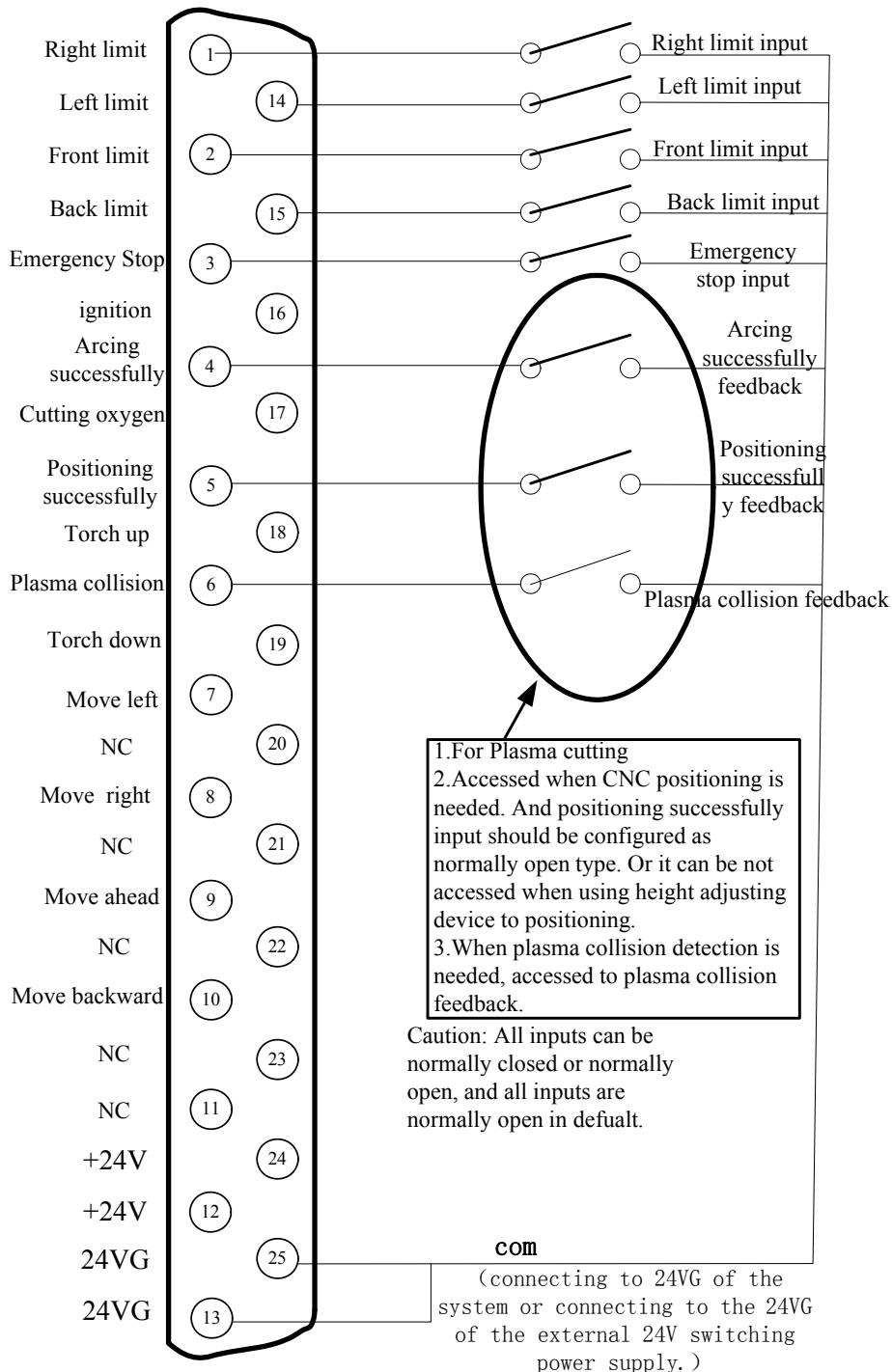

Fig 10.2 External input terminal

10.1.2 Remote Input

The system supports two external remote control input, one for line input type, the other for 8421 encoded input type.

➤ Line Input Type

The pin 7, 8, 9, 10 of input port represents left, right, forward, backward, when inputting valid signal, the machine can move toward the corresponding direction, when the input signal is invalid, the machine stop moving.

When the input signal of pin 16 is valid, the system will ignite the torch, the ignition time is the setting value in system parameters, please take the reference of part of "ignition time" in "7.2 oxygen gas parameters".

When the input signal of pin 17 is valid, the system will turn on or off the cutting oxygen. When the cutting oxygen is on, the system cut off the oxygen, when the cutting oxygen is off, open the cutting oxygen system.

When the input signal of pin 18 is valid, the system will raise the cutting torch, when the signal invalid, the torch stops.

When the input signal of pin 19 is valid, the torch goes down, when the signal invalid, the cutting torch stops.

The external switches of line input are designed by the user..

➤ 8421 code input

Input pin 9, 10, 7, 8 is the A, B, C, D bits of the 8421 code. Functions are shown in Table 10.2

Table 10.2 function of 8421 code input

Decimal	8421 code(DCBA)	Function
0	0000	No Input
1	0001	Turn on or off the cutting oxygen
2	0010	Go back according to the original track
3	0011	Move forward according to the original track
4	0100	Left lateral movement
5	0101	Ignite Input
6	0110	Start

7	0111	Slow down
8	1000	Accelerate
9	1001	Move for the negative direction vertically
10	1010	Move forward vertically
11	1011	Pause
12	1100	cutting torch
13	1101	raise the cutting torch
14	1110	Move toward right horizontally
15	1111	Start

8421-type remote control input is designed by the user, the user can also use the company's wireless remote control module.

10.1.3 Input Configuration

The number and type of input port can be reconfigured. For example, the right input port can be Pin 1, also can be configured to Pin 7, input type can be normally open type, can also be normally close type. Configuration methods are shown in Fig 10.3.

Press F5 (Diagnosis), F8 (SystemDef), F3 (Define), enter the password"1396"and press ENTER. in turn on the main Interface

Definition of input					
	Port	Type		Port	Type
Forward limit	02	●	Up move input	09	●
Back limit	15	●	Down move input	10	●
Left limit	14	●	Left move input	07	●
Right limit	01	●	Right move input	08	●
Sharpstop	03	●	Acceleration input	16	●
ArcFeedback	04	●	Deacceleration input	17	●
PosFeedback	05	●	Torch up input	18	●
PlasmaCrash	06	●	Torch down input	19	●

Port- Press PgUp/PDn Type-Press Enter

F1 Input	F2 Output	F3 Axes	F4 Motor				F8 Save
----------	-----------	---------	----------	--	--	--	---------

Fig10.3 Input Port Configuration

In the input configuration interface, move the cursor to numbers of the serial number, Press the PgUp or PgDn to change the input port number, which also change the pin number of 25-pin input terminal. Move the cursor to ● place, you can press ENTER to change the input type. “●” is for the normally open type of the input , when invalid , it is for the signal of turning off, when effective, it is for the signal of closure. “○” is the normally closed type of input , when invalid ,it is the signal of closure, when effective ,it is the signal of turning off.

10.2 Output Port

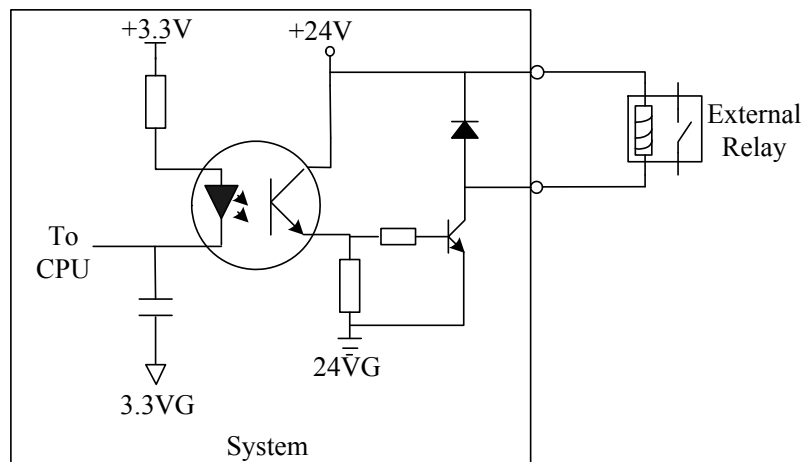

Fig10.4 output port circuit

- Output voltage is 24VDC, low level is effective;
- Maximum output current $I_{\max} = 300mA$;
- 16 output ports totallu
- Output signal definition

25Chip interface connector)	Pin No.(Main	Signal	Remark
3		Ignite	
1		Low pressure preheat	
17		High pressure preheat	
4		Low pressure cutting oxygen	
5		Medium pressure cutting oxygen	
14		High pressure cutting oxygen	
2		Torch up	
15		Torch down	

6	Exhaust	
8	Enable high adjusting box	
19	Plasma locating	
16	Plasma arc starting	
18	Corner low-speed output Or automatic / manual	
07	Spray dust	
20	Raise dust	
21	Dusting Preheat	
9, 10, 22, 23	Not used	
11,12,24	+24V	+24V/3Aoutput
13,25	24VG	+24Vground

10.2.1 Output Wiring Instructions

10.2.1.1 oxygen gas typical connection

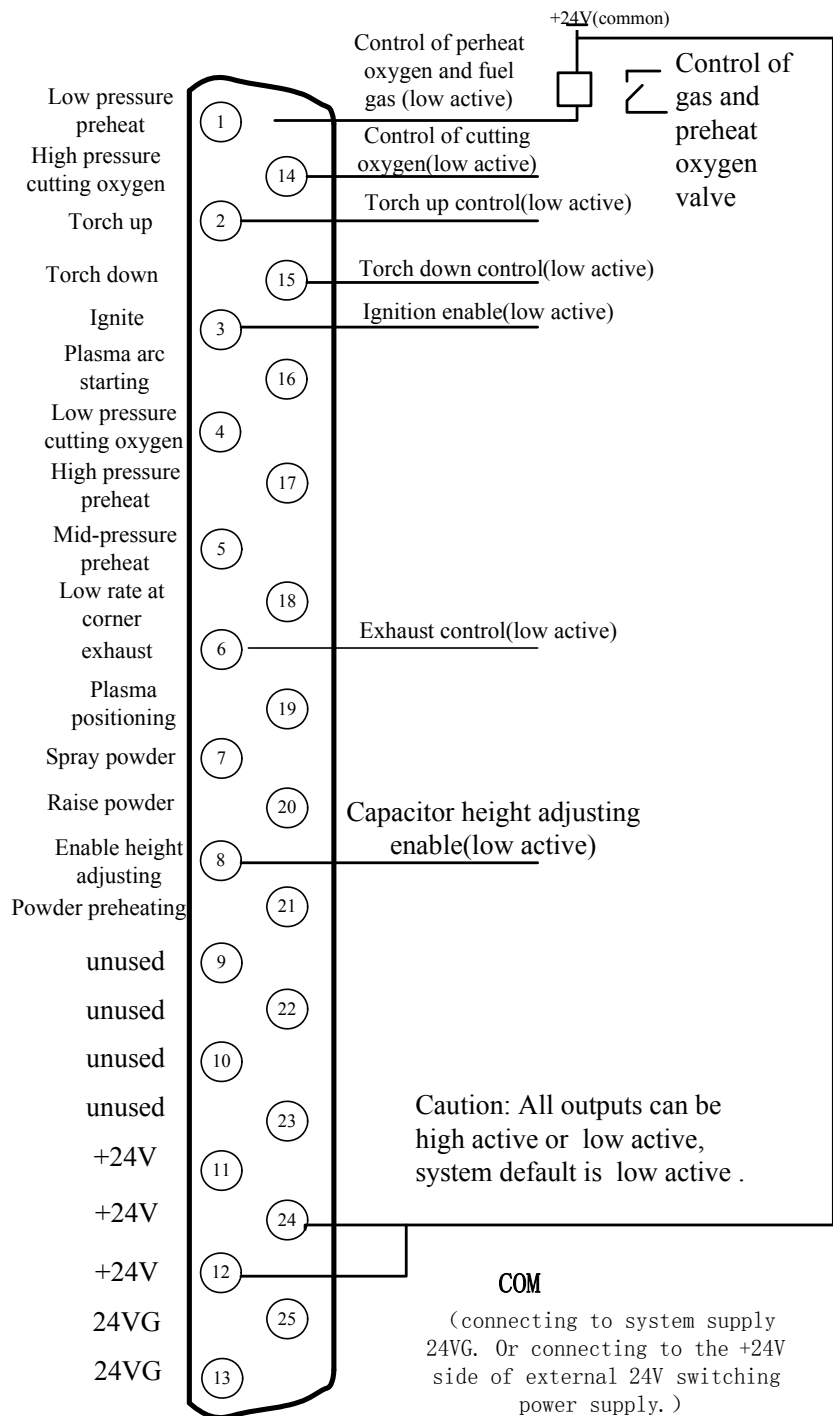

Fig10.5 oxygen gas typical connection

10.2.1.2 Three level perforation circuit

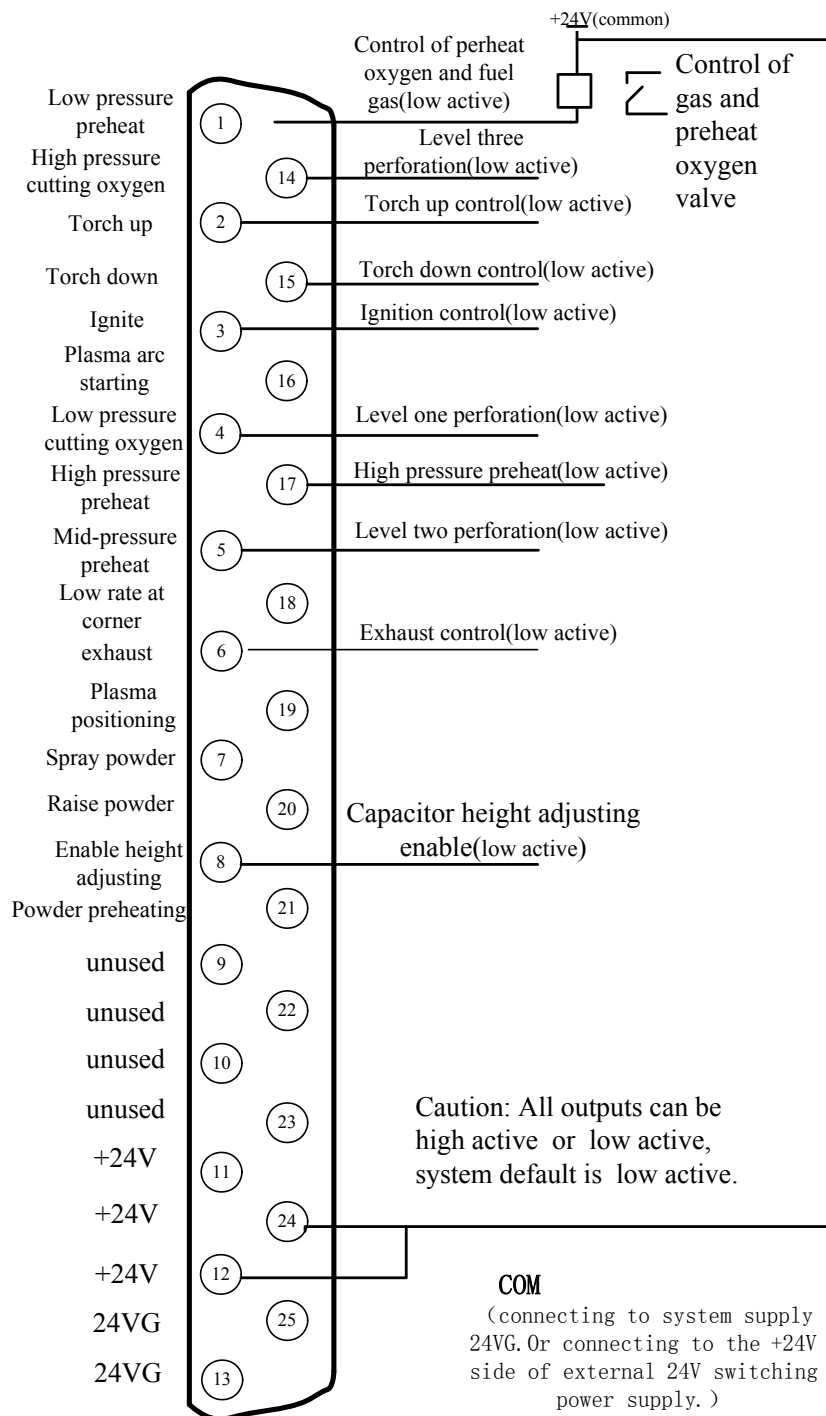

Fig 10.6 three level perforation circuit

10.2.1.3 Typical circuit of using powder

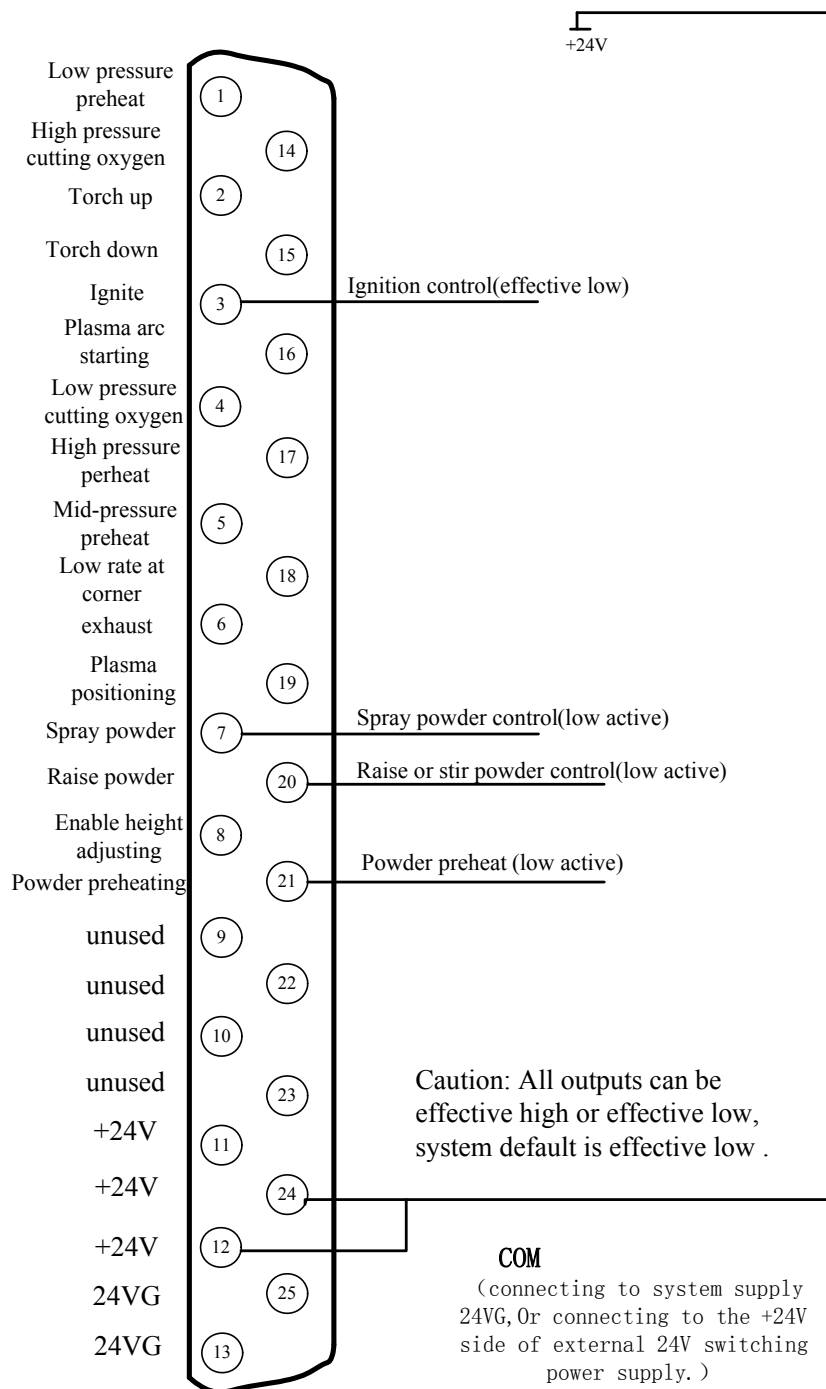

Fig 10.7 powder typical circuit

10.2. 1.4 typical circuit of using plasma cutting

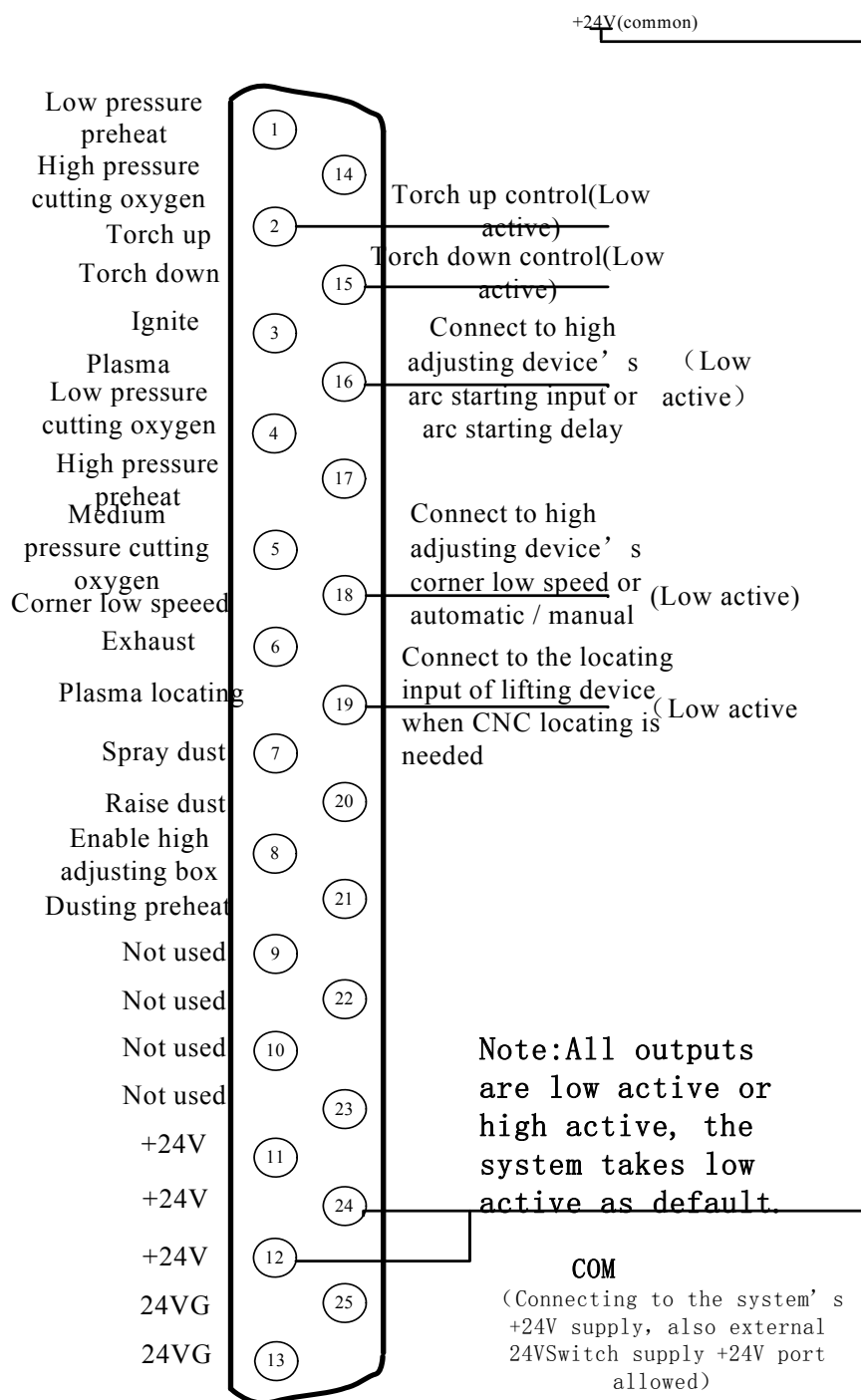

Fig 10.8 Typical wiring diagram of the plasma

Instruction:

➤ **THC wiring with corner low-speed(Corner signal/Torch height control signal)**

When the THC takes corner low-speed input control signal, the HYD-2100 "corner low speed" output signal is used to control the THC's corner low-speed input(Auto mode enable/disable signal). The CNC signal is an open-collector transistor output, with the default low-level effective. When the THC is not matched type, it needs to be converted by the relay.

THC wiring with automatic / manual

When THC is automatic / manual control function instead of corner low-speed input, the system needs to use the "corner low-speed" output to control the THC's automatic / manual signal. When the THC is not matched type, it needs to be converted by the Relay. Meanwhile, it needs to change the type of corner low speed from normally-open to normally-closed in the output configuration interface (Section 10.2.2), i.e from red "●" to green "○".

➤ **Using THC for initial sense(IHS)**

When using the locating function of the THC, the locating of CNC should be closed. The approach is to change the input type of successful locating from normally-open to normally-closed in the input configuration interface(Section 10.1.3), i.e from "●" to "○". There are two types of locating:

The first: locating controlled by the plasma arc starting. CNC output the plasma arc starting, the THC starts arc after IHS, and sends ARC OK signal back to CNC after pierce. Such THC is available on the market like HYD's XPTHC series. Such devices can connect the "plasma arc starting" output of CNC system to the " arc on with IHS" input of the THC, and at the same time in the plasma parameters (refer to section 7.4 of plasma parameters) set the arc detecting time to the value that allows for completing the testing and starting arc.

Using CNC system locating

When using the Initial Sense function of CNC system, first entering the input configuration interface, set the input type of successful location from normally closed to normally open type, ie, from "○" to "●". At the same time, return the signal of successful location to the input of the successful location of the CNC.

10.2.2 Output configuration

The number and type of the output could be configured, for example, the igniting output number could be 3,also it could be configured to 07, the output type could be normally open or normally closed. The detailed methods are shown in figure 10.9.

Press F5(Diagnosis) in the main interface, F8(Systemdef), F3 (Define), enter the password "1396" and press ENTER, F2(output).

Definition of output					
	Port	Type		Port	Type
Ignition	03	●	Exhaust	06	●
LowPreheat	01	●	THC	08	●
HighPreheat	17	●	PosDetect	19	●
LowOxygen	04	●	ArcStart	16	●
MidOxygen	05	●	LowSpdInCorner	18	●
HighOxygen	14	●	Dust spray	07	●
TorchUp	02	●	Raise dust	20	●
TorchDown	15	●	Dust preheat	21	●

Port- Press PgUp/PDn Type-Press Enter

F1 Input	F2 Output	F3 Axes	F4 Motor				F8 Save
----------	-----------	---------	----------	--	--	--	---------

Fig 10.9 Output Configuration

In the output configuration interface, move the cursor to numbers of the serial number, Press the PgUp or PgDn to change the input port number, that also changes the pin number of 25-pin input terminal. Move the cursor to ● place, you can press ENTER to change the input type. "●" is for the normally open type of the input , when invalid , it is for the signal of turning off, when effective, it is for the signal of closure. "○" is the normally closed type of input , when invalid ,it is the signal of closure, when effective ,it is the signal of turning off.

10.3 Motor Port

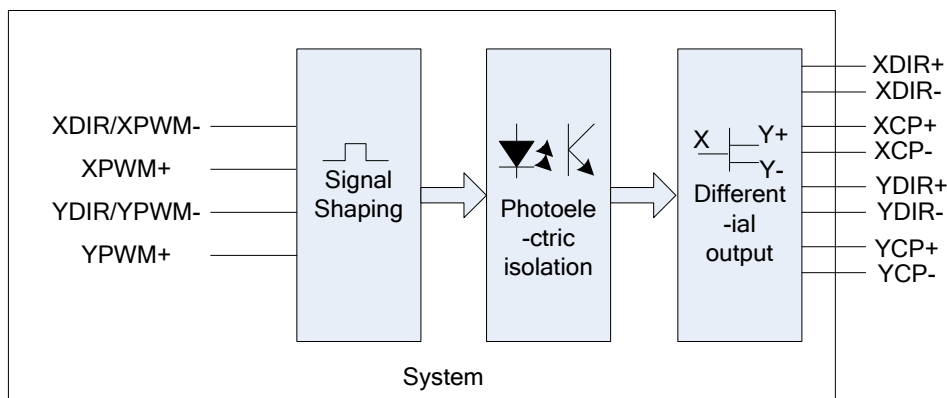

Fig10.10 motor port schematic diagram

● Signal definition table

Number of the 15 pin interface	signal	Remarks
1	XDIR+	Positive at the horizontal axis
9	XDIR-	Negative at the horizontal axis
2	XCP+	Positive pulse at the horizontal axis
10	XCP-	Negative pulse at the horizontal axis
3	YDIR+	Positive at the vertical axis
11	YDIR-	Negative at the vertical axis
4	YCP+	Positive pulse at the vertical axis
12	YCP-	Negative pulse at the vertical axis
5	ZCP+	Positive pulse at the perpendicular axis
13	ZCP-	Negative pulse at the perpendicular axis
6	ZDIR+	Positive at the perpendicular axis
14	ZDIR-	Negative at the perpendicular axis
7	+5V	+5V/500mA Power output
15,8	5VG	5V Power Ground

10.3.1 Typical wiring diagram of the electrical motor interfaces

10.3.1.1 connection methods for differential stepper driver

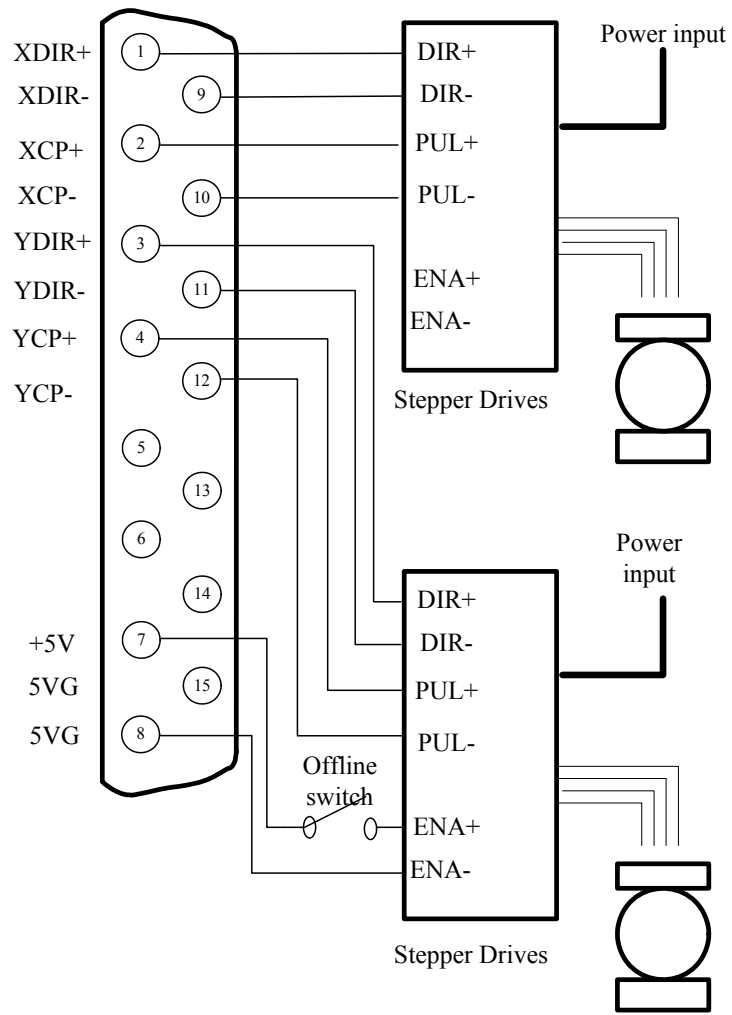

Fig 10.11 connection methods for differential stepper driver

10.3.1.2 Com -anode connection methods for stepper driver

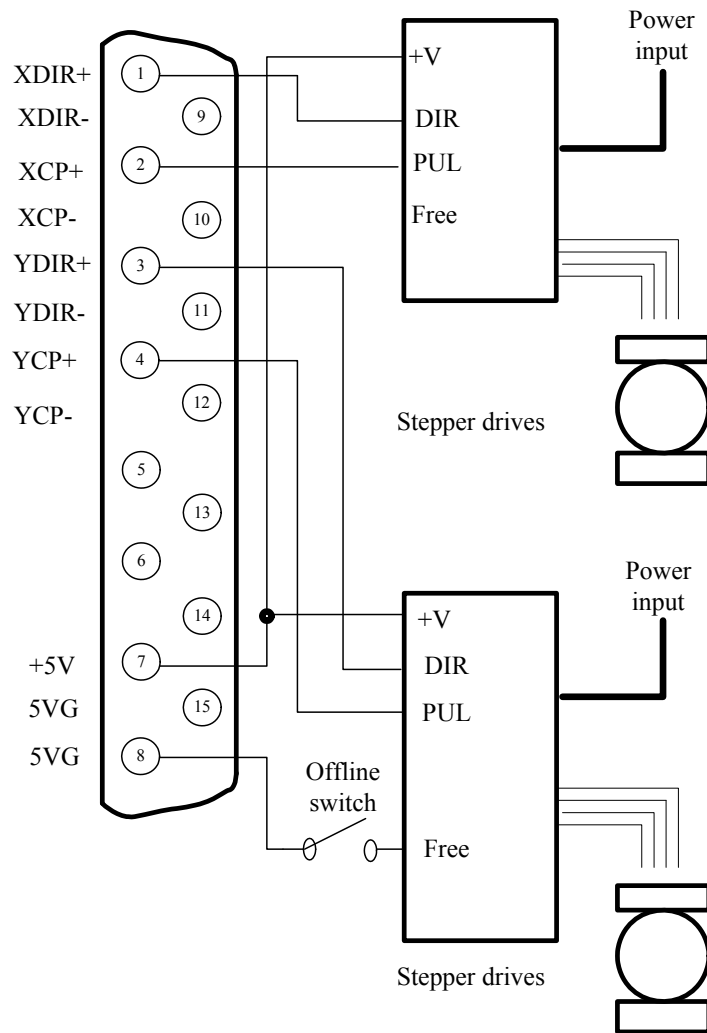

Figure 10.12 com-anode connection methods for stepper driver

10.3.1.3 Connection methods of Servo driver of Panasonic Company

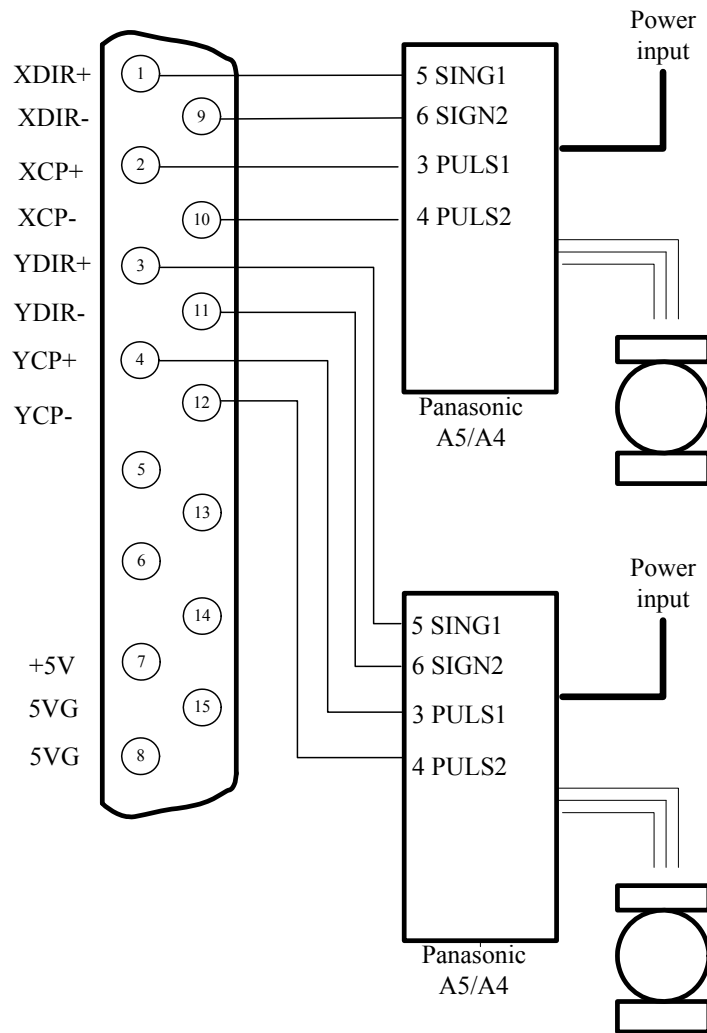

Figure 10.13 Connection methods of Servo driver of Panasonic Company

10.3.2 Coordinate Mapping

In order to change the map coordinates of the system, you need to go to the define interface. The process is to Press F5(Diagnosis) in the main interface, F8(Systemdef), F3 (Define), enter the password "1396" and press ENTER, then press F3 (Axes). As shown in Figure 10.14.

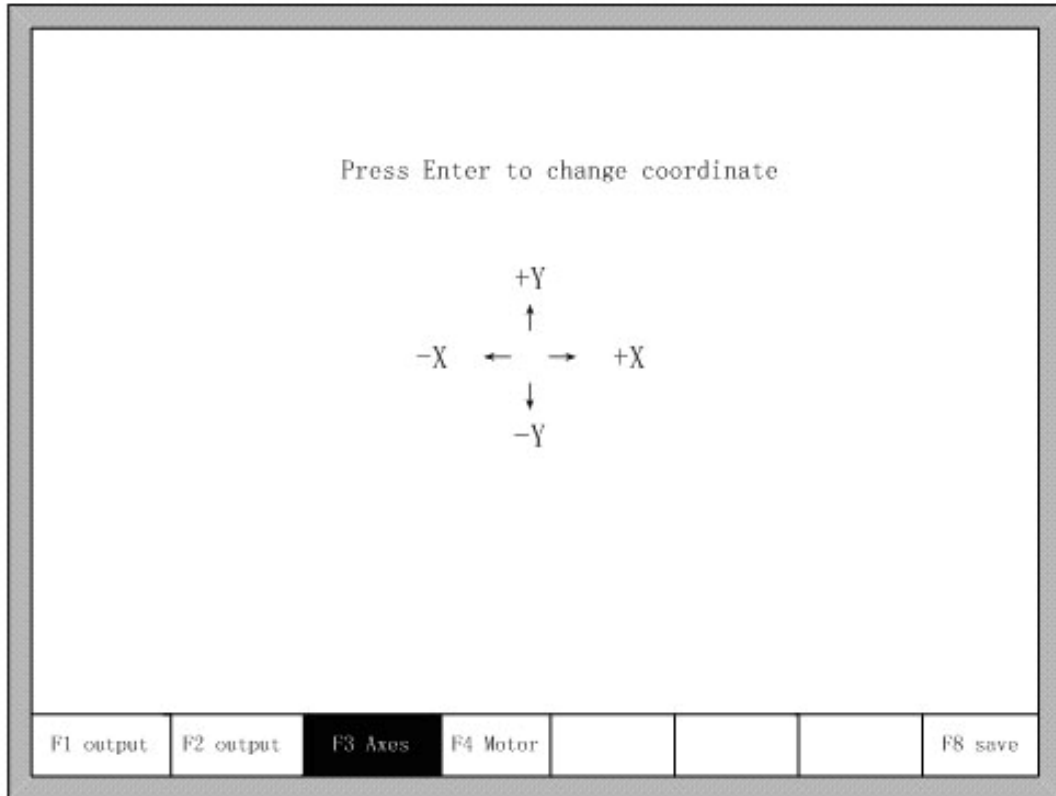

Fig 10.14 Coordinate Mapping

Continuously press **【Enter】** key, the direction of the arrow outside coordinates definition will change, the maximum coordinate mapping is eight. After adjusting the direction of the coordinates mapping, press F8 to Save.

Chapter11 Installation and Debugging

11.1 Horizontal / vertical pulses number setting

- Horizontal / vertical pulses number setting

It's easy to set the horizontal(vertical) pulses number. Before drawing a line , assume one value of horizontal pulses XPls and one value of vertical pulses YPls, set these two parameters and then save the settings. Enter the manual interface, choose fixed moving function. Assume the fixed distance is Amm. Move A mm horizontally, and the actual length of the line is B mm (which is generally not equal to A), then we can calculate the horizontal pulses number. The equation is

$XPls \bullet \frac{A}{B}$. After calculating , replace the outcome with the assumptive Xpls(take three decimal places at most). Similarly, move C mm vertically, the actual length is D mm, then the vertical

pulses number is $YPls \bullet \frac{C}{D}$.

- requirement of pulses number:

The maximum frequency of output pulses from the system is 200 KHz. It is not possible to work properly according to the order if the pulse frequency is higher than 200KHz. Assume the pulse number is x, the highest speed is Mv (mm/min), then (Mv*x/60) should be less than 200000.

For example, the pulse number is x=2000, the highest speed is Mv=12000(mm/min).Because of $Mv*x/60=12000*2000/60=400000>200000$, the speed of 12000(mm/min) is not reachable. If we set x to be 1000, then $Mv*x/60 = 12000*1000/60 = 200000$, this time it can just to reach the operating speed of 12,000. While in principle the number of pulses can be set to a large value, in fact it should follow these two settings. Because the frequency is too high, some drives can't work very well, the motor will be out of synchronism. On the other hand, the performance of anti-jamming is of foreign interference is poor, and the external interference is strong.

Chapter12 The use of BIOS

When the system powers on, it will display as shown in Fig 12.1.

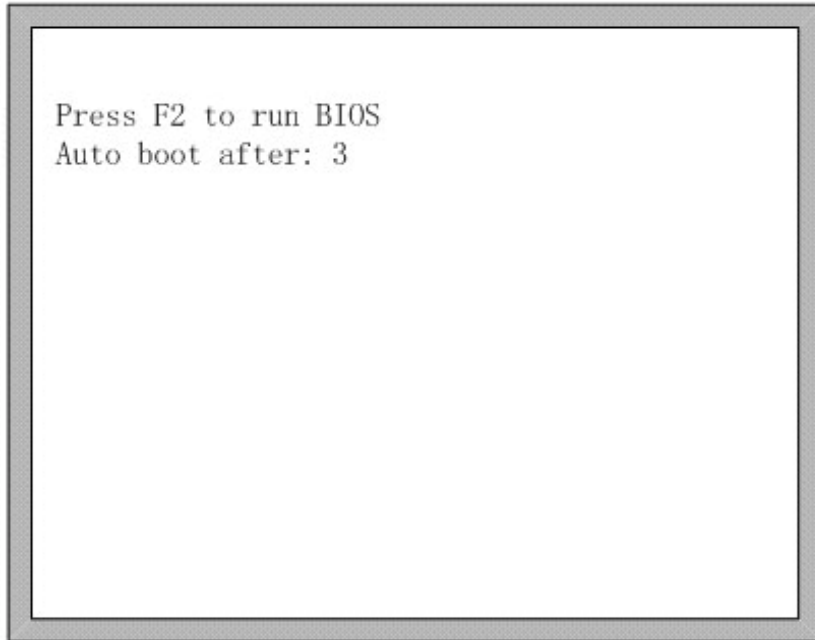

Fig 12.1 power on

When press DEL before the system counts down to 0, the system will enter the BIOS. If other keys are pressed, the system will enter in before counting down to 0.

- F1 - 系统升级(System software update)
- F2 - 欢迎界面升级(Welcome picture update)
- F3 - 运动控制升级(Motion update)
- F4 - 系统备份(System backup)
- F5 - 系统还原(System recovery)
- F6 - 启动系统(Start system)

Fig 12.2 BIOS interface

12.1 System upgrade

After entering BIOS, press F1 to upgrade the system, it should satisfy the following conditions:

Flash Disk is connected to the system.

There should be the UserApp.exe upgrade file in the root folder of the flash disk.

Pressed F1 to upgrade when the conditions are satisfied, when completing the upgrading, press F6 to reboot.

12.2 Welcom interface upgrading

After entering BIOS, press F2 to upgrade the welcome interface completely, it should satisfy the following conditions:

- Flash Disk is connected to the system.
- There should be the STARTBMP.BIN upgrade file in the root folder of the flash disk.

Pressed F6 to upgrade when the conditions are satisfied, when completing the upgrading, press F6 to reboot.

12.3 Movement control upgrade

After entering BIOS, press F2 to upgrade the welcome interface completely, it should satisfy the following conditions:

- Flash Disk is connected to the system.
- There should be the MOTION.DSP upgrade file in the root folder of the flash disk.

Pressed F3 to upgrade when the conditions are satisfied, when completing the upgrading, press F6 to reboot.

12.4 Movement Backup

after entering BIOS, press F4 to backup.

12.5 System Reset

After entering BIOS, press F5 to return to the original system that has been backup.

Appendix 1 G、M code rapid consult

Serial number	order	function
1	G99	rotation、 proportion、 mirror image
2	G92	reference coordinate
3	G91	Relative coordinate system
4	G90	Absolute coordinate system
5	G20	English unit
6	G21	Metric unit
7	G41	Left kerf gap compensation
8	G42	Right kerf gap compensation
9	G40	Cancel kerf gap compensation
10	G00	Quickly move
11	G01	Liner cutting
12	G02	Clockwise arc cutting
13	G03	Anticlockwise arc cutting
14	G04	Program delay
15	M07	Start cutting cycle
16	M08	Stop cutting cycle
17	M02	Program end
14	G04	Program delay
15	M07	Start cutting cycle
16	M08	Stop cutting cycle
17	M02	Program end